

2 - Wash Hood 900mm

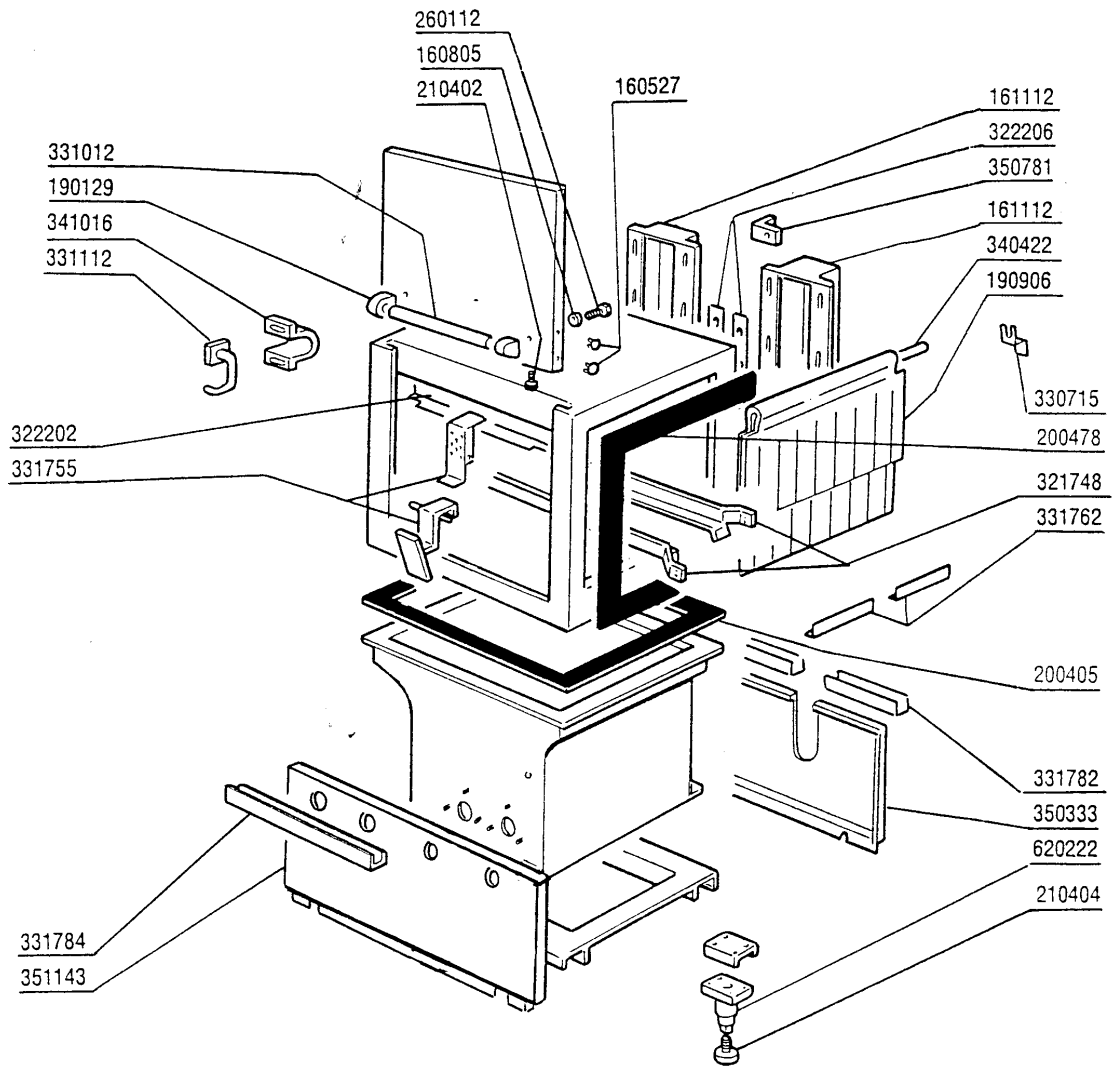

2 - Wash Hood 900mm

CODE	DESCRIPTION
160527	PLUG 14,5X2X8
160805	GASKET D.8
161112	BACK COVER CHANNEL 300 S N
190129	HANDLE SUPPORT SE NE GREY
190906	CURTAIN IN/OUT 620X480
200405	GASKET 110X100X63 IN NEOTEN
200478	SELF-ADHESIVE GASKET 65X4
210402	PAD FOR DOOR 15-149
210404	BLACK RUBBER FOOT S90 NE SE
260112	STAINLESS STEEL TE-SCREW 8X16
321748	GUIDE
322202	.
322206	HOOD REENFORCER
330715	UPPER BRACKET CURTAIN SNL-SE
331012	HANDLE 412 MM DOOR SE NE G115
331112	HOOK (331116)
331755	HOOK FOR DOOR SUPPORT
331762	BRACKET SPLASH GUARD
331782	PANEL SUPPORT 237MM
331784	PANEL SUPPORT 775MM
340422	SHAFT FOR CURTAIN AC-ACR
341016	BRACKET FOR DOOR SECURITY HOOK
350333	WASH PANEL
350781	BRACKET
351143	FRONT PANEL WASH ACR
620222	COMPLETE ALUMINIUM LEGS

3 - Hood Ecorinse 600mm

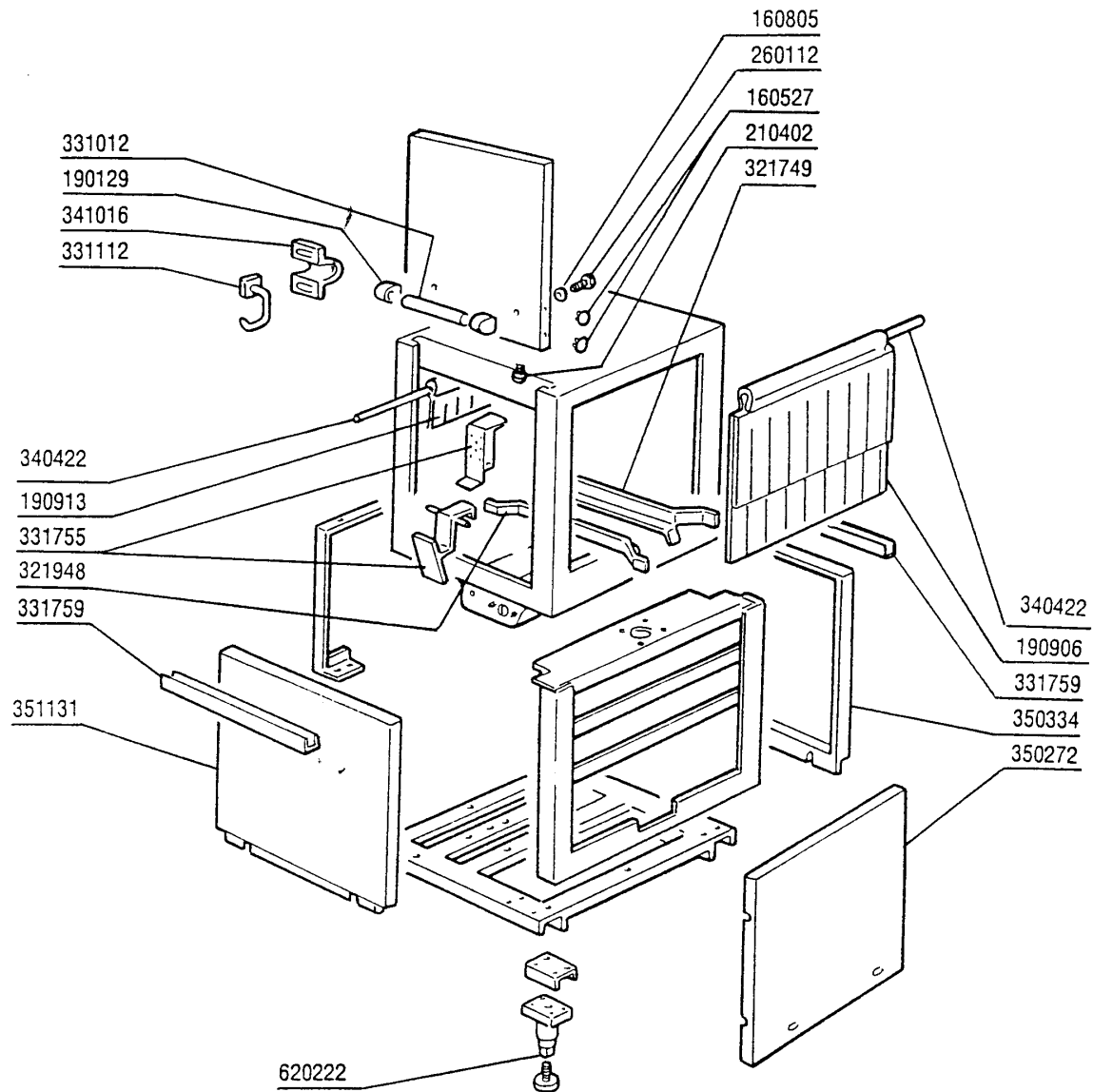

3 - Hood Ecorinse 600mm

CODE	DESCRIPTION
160527	PLUG 14,5X2X8
160805	GASKET D.8
190129	HANDLE SUPPORT SE NE GREY
190906	CURTAIN IN/OUT 620X480
190913	CURTAIN FOR ECORINSE SE-620X27
210402	PAD FOR DOOR 15-149
260112	STAINLESS STEEL TE-SCREW 8X16
321749	GUIDE
321948	GUIDE
331012	HANDLE 412 MM DOOR SE NE G115
331112	HOOK (331116)
331755	HOOK FOR DOOR SUPPORT
331759	SUPPORT
340422	SHAFT FOR CURTAIN AC-ACR
341016	BRAKET FOR DOOR SECURITY HOOK
350272	PANEL
350334	ECORINSE PANEL
351131	PANEL
620222	COMPLETE ALUMINIUM LEGS

4 - Blower Dryer hood

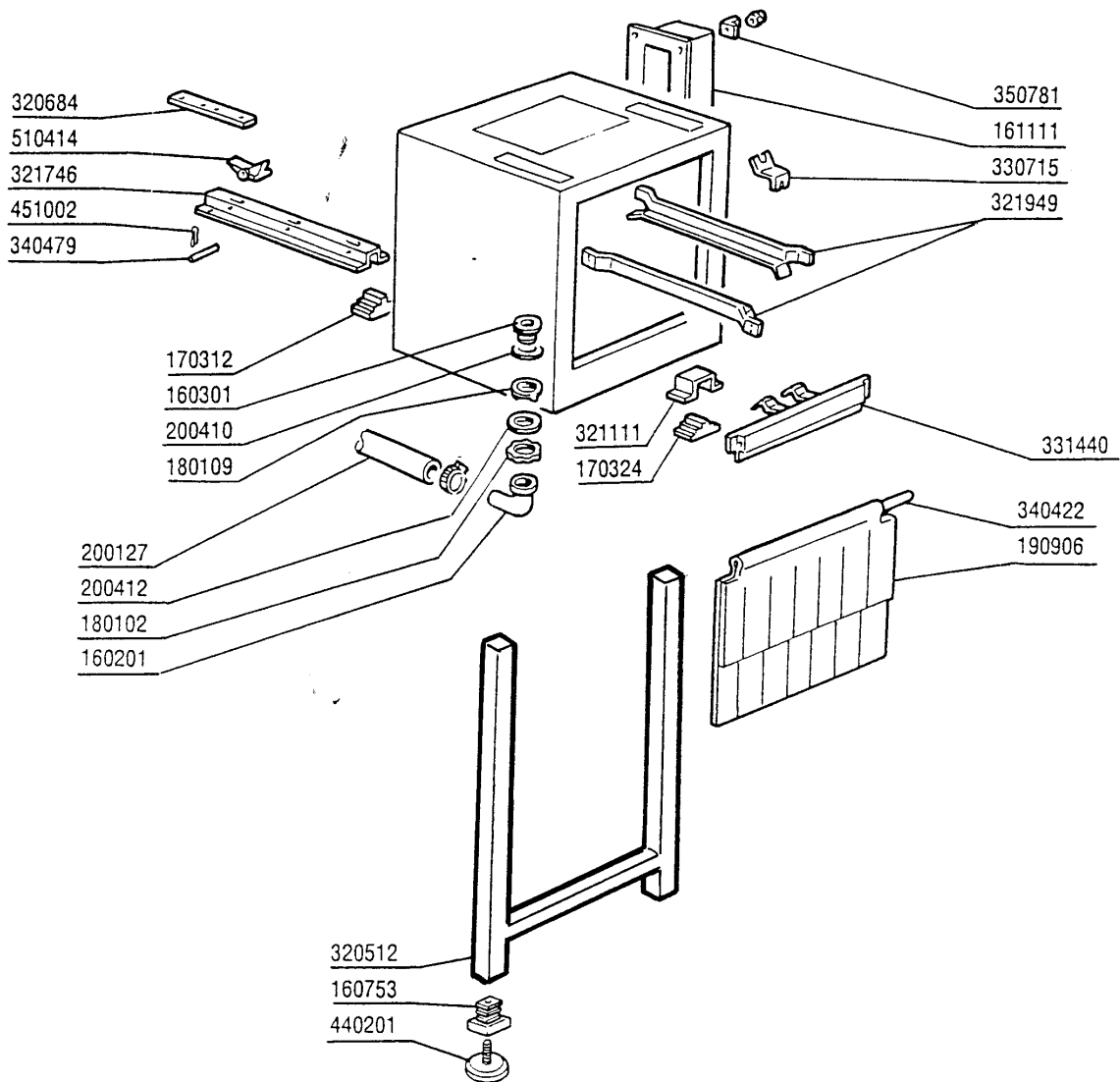

4 - Blower Dryer hood

CODE	DESCRIPTION
160201	ELBOW F.TANK INLET MOPLEN
160301	DRAIN OUTLET 1"1/2 C-S-N
160753	PLUG 40X40X1
161111	BACK COVER CHANNEL 130 N S2900
170312	SUPPORT F.PAWL BAR GUIDE S90-
170324	GUIDE SUPPORT SE-S2200-290
180102	DRAIN PIPE NUT 1"1/2 F45-55
180109	LOCK NUT 1 1/2"
190906	CURTAIN IN/OUT 620X480
200127	PVC HOSE D.35
200410	DRAIN OUTL.WASH.1 1/2"65X47X2
200412	GASKET DRAIN 11/2" 45X33X3
320512	TABLES LEG
320684	BRACKET
321111	COVER
321746	GUIDE
321949	GUIDE
330715	UPPER BRACKET CURTAIN SNL-SE
331440	PANEL
340422	SHAFT FOR CURTAIN AC-ACR
340479	PAWL PINS SNL-SE
350781	BRACKET
440201	RUBBER FOOT D.60X10
451002	COTTER PIN STAINL.ST. D2X12
510414	NICKEL-PLATED PAWL SNL-SE

5 - Prewash Assembly 600mm

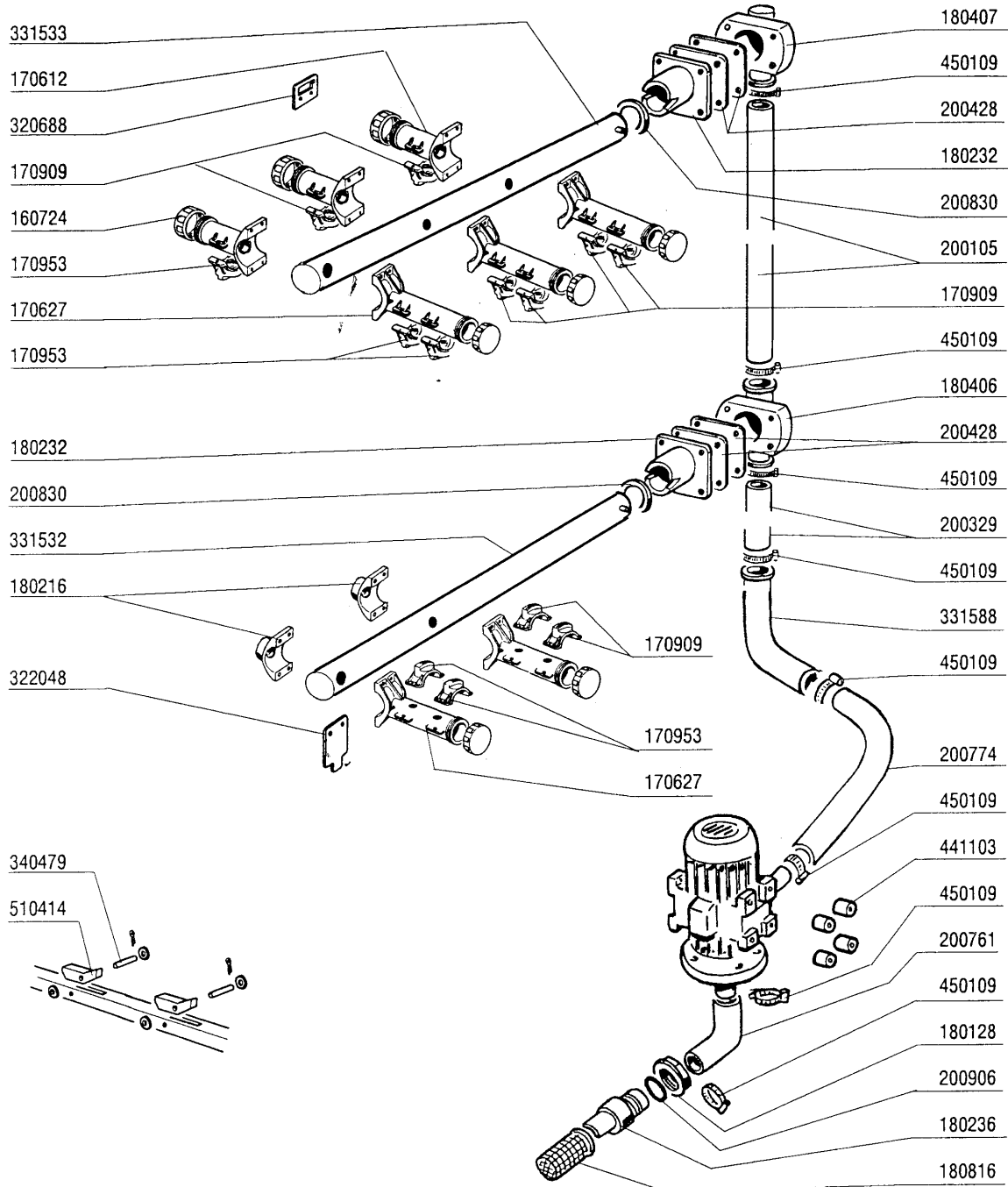

5 - Prewash Assembly 600mm

CODE	DESCRIPTION
160724	PLUG F. WASH ARM S90
170612	SHORT WASH ARM S90-S2900
170627	2-JETS WASH ARM FOR AC
170909	TRANSVERS. WASH NOZZLE
170953	PRE-WASH JET S NL
180128	RING NUT 65,4 C140 C85
180216	WASH ARM COUNTERFLANGE S90-S N
180232	WASH ARM FLANGE SNL
180236	PUMP SUCTION FOR AC-ACR-C155
180406	T-CONNECTOR F. WASHING S90-SNL
180407	ELBOW S90 S N L
180816	STRAINER OF INLET PUMP AC-ACR
200105	RUBBER HOSE 50X60
200329	HOSE
200428	GASKET 100X100X3 NEOTEN
200761	INLET HOSE - PREWASH AC -
200774	DELIVERY HOSE PREWASH AC
200830	O-RING 37,3X44,5X3,6
200906	GASKET D.92X66X2
320688	SUPPORT FOR S/AC WASHARM
322048	BRACKET
331532	LOWER WASH ARM AC91/101
331533	UPPER WASH ARM AC91/101
331588	HOSE (332223)
340479	PAWL PINS SNL-SE
441103	PUMP FEET
450109	CLAMP 50-65
510414	NICKEL-PLATED PAWL SNL-SE

6 - Corner Prewash Assembly

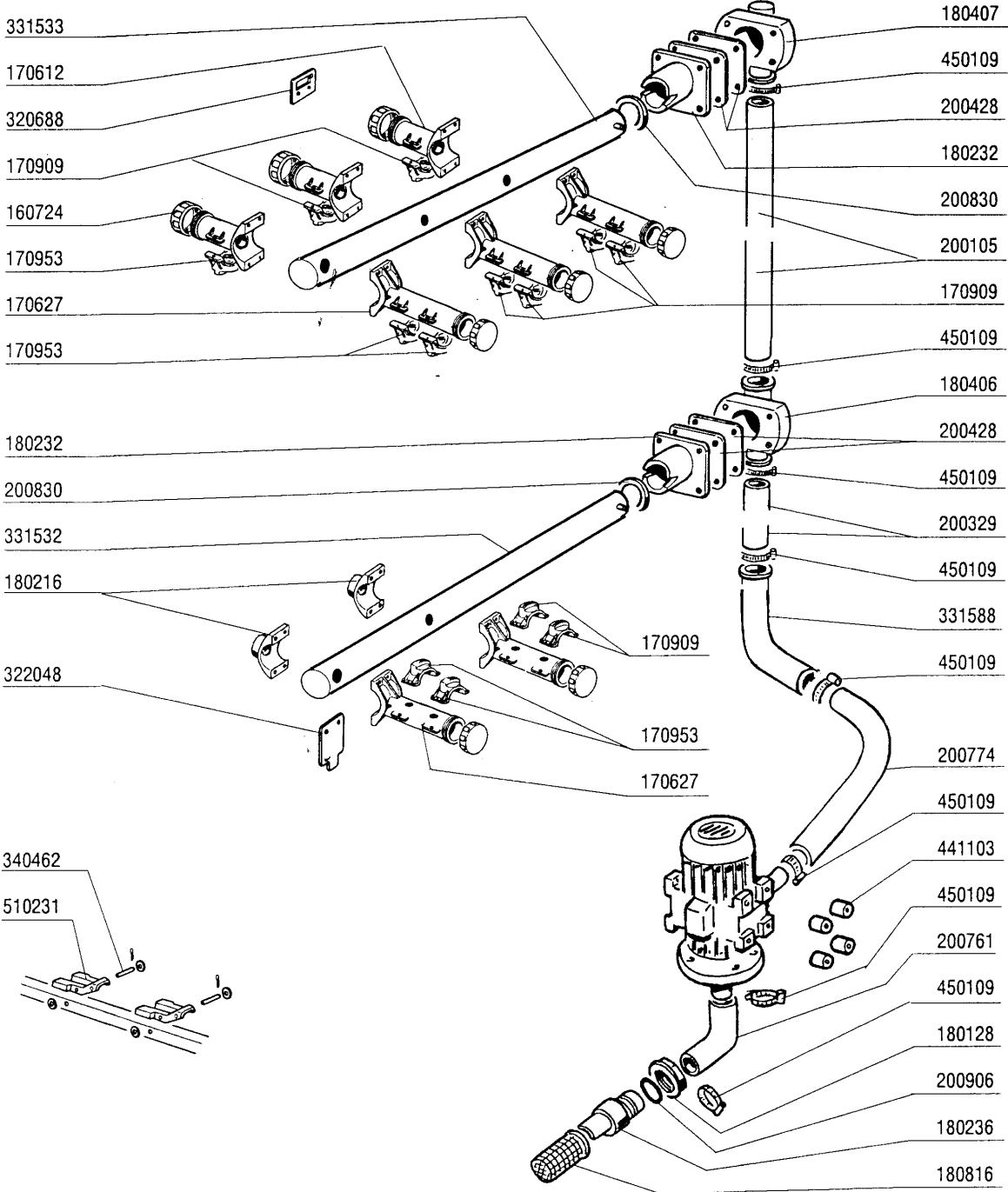

6 - Corner Prewash Assembly

CODE	DESCRIPTION
160724	PLUG F. WASH ARM S90
170612	SHORT WASH ARM S90-S2900
170627	2-JETS WASH ARM FOR AC
170909	TRANSVERS. WASH NOZZLE
170953	PRE-WASH JET S NL
180128	RING NUT 65,4 C140 C85
180216	WASH ARM COUNTERFLANGE S90-S N
180232	WASH ARM FLANGE SNL
180236	PUMP SUCTION FOR AC-ACR-C155
180406	T-CONNECTOR F. WASHING S90-SNL
180407	ELBOW S90 S N L
180816	STRAINER OF INLET PUMP AC-ACR
200105	RUBBER HOSE 50X60
200329	HOSE
200428	GASKET 100X100X3 NEOTEN
200761	INLET HOSE - PREWASH AC -
200774	DELIVERY HOSE PREWASH AC
200830	O-RING 37,3X44,5X3,6
200906	GASKET D.92X66X2
320688	SUPPORT FOR S/AC WASHARM
322048	BRACKET
331532	LOWER WASH ARM AC91/101
331533	UPPER WASH ARM AC91/101
331588	HOSE (332223)
340462	SHORT TRAY CARRIER PIN GM-S290
441103	PUMP FEET
450109	CLAMP 50-65
510231	PAWL /CORNER LOAD.

7 - Wash Assembly 900mm

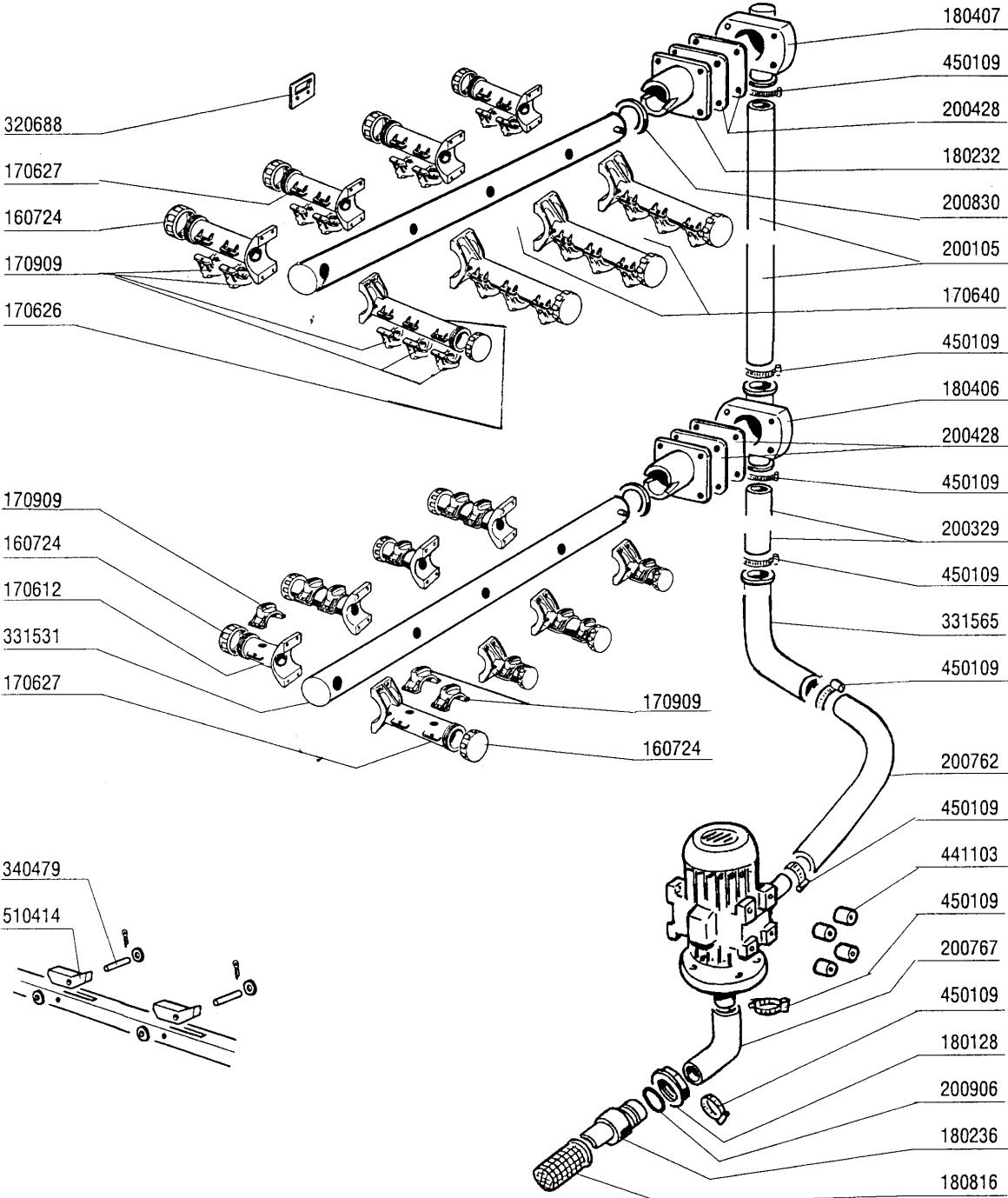

7 - Wash Assembly 900mm

CODE	DESCRIPTION
160724	PLUG F. WASH ARM S90
170612	SHORT WASH ARM S90-S2900
170626	3-JETS WASH ARM FOR AC
170627	2-JETS WASH ARM FOR AC
170640	WASH ARM 3 JETS - AC -
170909	TRANSVERS. WASH NOZZLE
180128	RING NUT 65,4 C140 C85
180232	WASH ARM FLANGE SNL
180236	PUMP SUCTION FOR AC-ACR-C155
180406	T-CONNECTOR F. WASHING S90-SNL
180407	ELBOW S90 S N L
180816	STRAINER OF INLET PUMP AC-ACR
200105	RUBBER HOSE 50X60
200329	HOSE
200428	GASKET 100X100X3 NEOTEN
200762	DELIVERY HOSE ACR
200767	OUTLET HOSE WASH ACR
200830	O-RING 37,3X44,5X3,6
200906	GASKET D.92X66X2
320688	SUPPORT FOR S/AC WASHARM
331531	UPPER WASH ARM SNL
331565	INLET ELBOW FOR AC/ACR WASH PU
340479	PAWL PINS SNL-SE
441103	PUMP FEET
450109	CLAMP 50-65
510414	NICKEL-PLATED PAWL SNL-SE

8 - Ecorinse Assembly

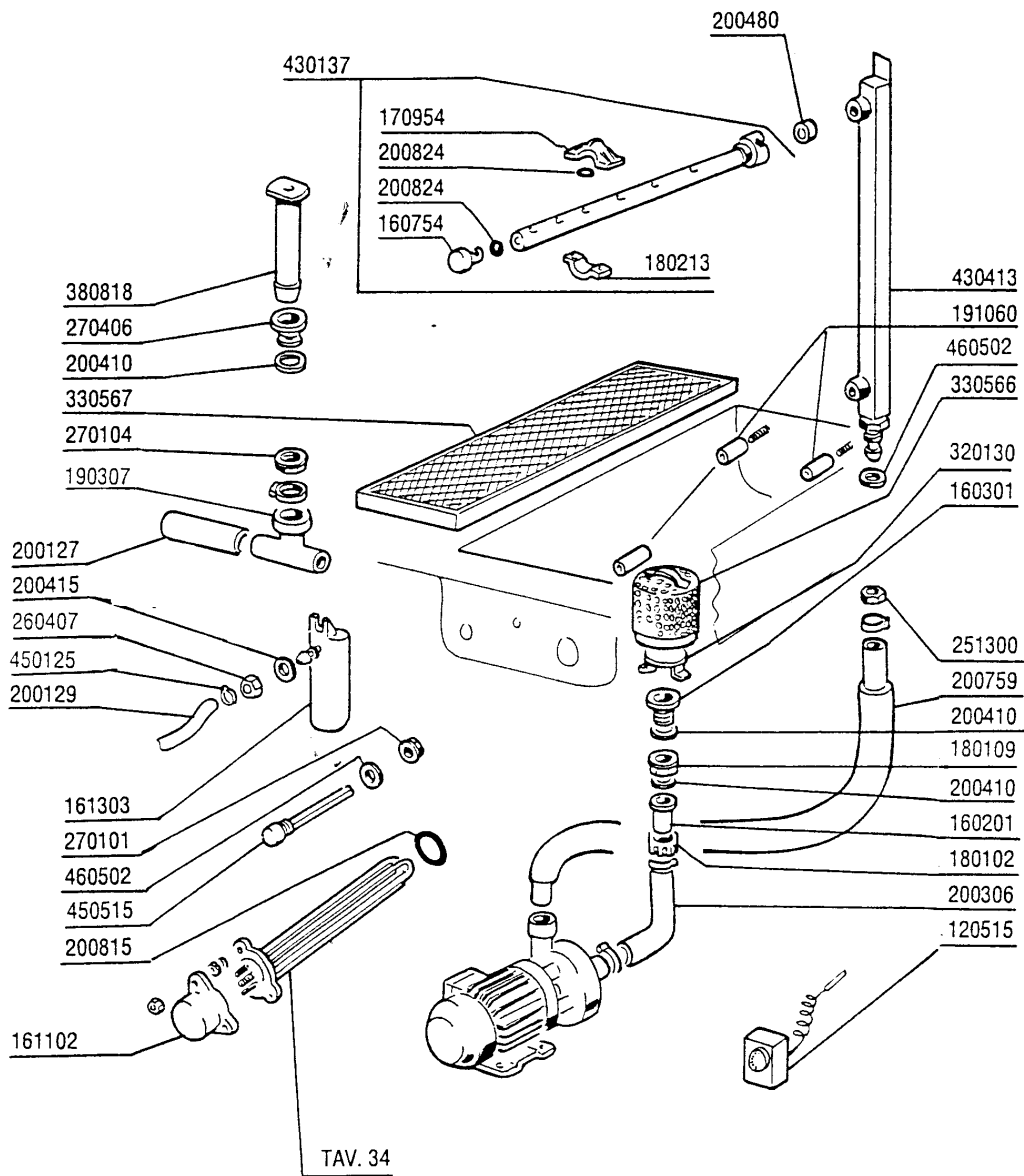

8 - Ecorinse Assembly

CODE	DESCRIPTION
120515	THERMOSTAT 0-90°C
160201	ELBOW F.TANK INLET MOPLN
160301	DRAIN OUTLET 1"1/2 C-S-N
160754	PLUG FOR RINSE ARMS SE NE
161102	ELEMENT COVER MOPL.
161303	AIR TRAP GLASSWASHER
170954	JET FOR ECORINSE ARM
180102	DRAIN PIPE NUT 1"1/2 F45-55
180109	LOCK NUT 1 1/2"
180213	FLANGE F.JET LOCKING F2-C34
190307	SPECIAL TEE GRAU MPL.
191060	HOLDER PIN FOR ECORINSE FILTER
200127	PVC HOSE D.35
200129	HOSE 5X11 FOR PRESSURE SWITCH
200306	INLET HOSE 42X52 ECORINSE-DRAI
200410	DRAIN OUTL.WASH.1 1/2"65X47X2
200415	AIR TRAP GASKET -F2 18,5X10X3
200480	GASKET F. RINSE CONNECT.
200759	DELIVERY HOSE FOR ECORINSE AC-
200815	O-RING F. HEAT.ELEM.
200824	O-RING 1,78X12,42X15,98
251300	S/S LOCK NUT 1/2" AC-ACR
260407	STAINLESS STEEL NUTS D10 UNI 5
270101	HEXAGON LOCK NUT 1/2"
270104	LOCK NUT 1" 1/2
270406	ECORINSE DRAIN OUTLET
320130	VORTEX BREAKER FOR ECORINSE PU
330566	FILTER 110 FOR ECORINSE TANK
330567	STANDARD RINSE FILTER SE
380818	OVERFLOW TUBE FOR ECORINSE SE
430137	ECORINSE ARM SE-SE/1
430413	RINSE COLUMN SE-ACR
450125	ELASTIC CLAMP D. 10,4X9,8
450515	STAINL.ST.SHIELD FOR 1 THERMOS
460502	GASKET 30X21X2

9 - Rinse assembly

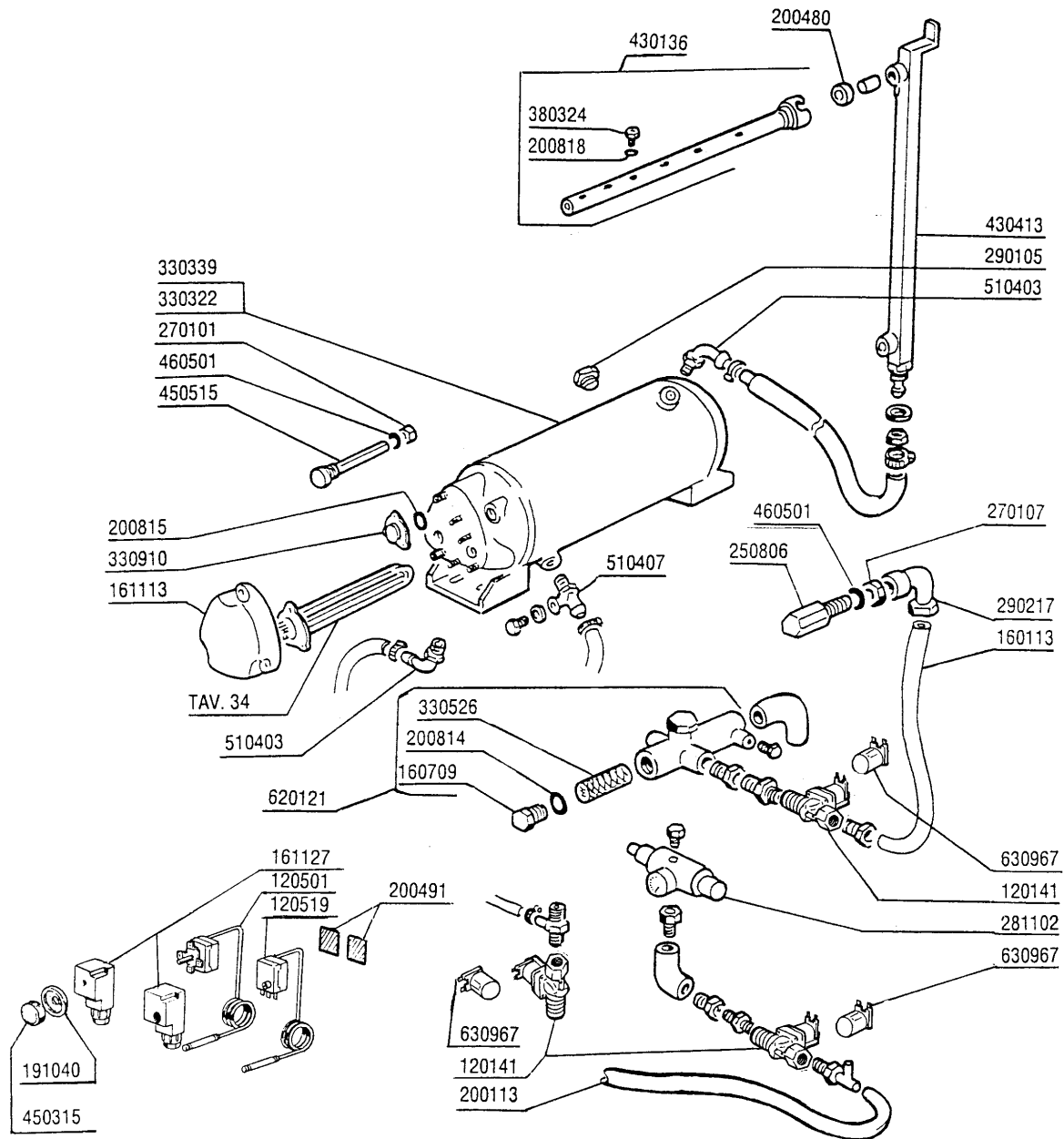

9 - Rinse assembly

CODE	DESCRIPTION
120141	SOLE.N.VALVE METAL.328000 D.1/2
120501	THERMOSTAT 30/90ØC
120519	SECURITY THERMOSTAT 95-125Ø
160113	TUBE IN POL. RETIC. 12 EST
160709	KNOB OF MANIFOLD F. SOLEN. VAL
161113	ELMENT COVER BLACK
161127	BOX FOR THERMOSTAT
191040	FRAME F.THERMOSTAT KNOB
200113	RUBBER HOSE 12 X 22
200480	GASKET F. RINSE CONNECT.
200491	BACK GASKET OF THERMOSTAT BOX
200814	O-RING 34,52X41,58X3,53
200815	O-RING F. HEAT.ELEM.
200818	O-RING 1,78 X 6,75 X 10,31
250806	TANK FILL HOSE CLAMP - AC/ACR
270101	HEXAGON LOCK NUT 1/2"
270107	BRASS LOCK NUT 3/8" FL803
281102	1/2" ADJ VALVE C/W GAUGE TYPE
290105	BRASS-TE-PLUG 1/2"
290217	HOSE CLAMP ELBOW 12X3/8" TYPE
330322	INSULATED BOILER D.230 N/S
330339	BOILER D.220X640 F.TWO HEAT.EL
330525	STRAINER (330537)
330910	FLANGE
380324	RINSE JETS 52,5 80Ø OV1/8"
430136	RINSE ARM S-SE-SE/1
430413	RINSE COLUMN SE-ACR
450315	KNOB F. THERMOSTAT 90Ø
450515	STAINL.ST.SHIELD FOR 1 THERMOS
460501	GASKET 24X17X2
510403	CONNECT.HOSE 90Ø1/2"X12
510407	NIPPLE FOR BOILER N S
620121	TWIN SOLENOID VALVE MANIFOLD
630967	COIL V24/50HZ E/V 328002

10 - Wash Tank Components 900mm

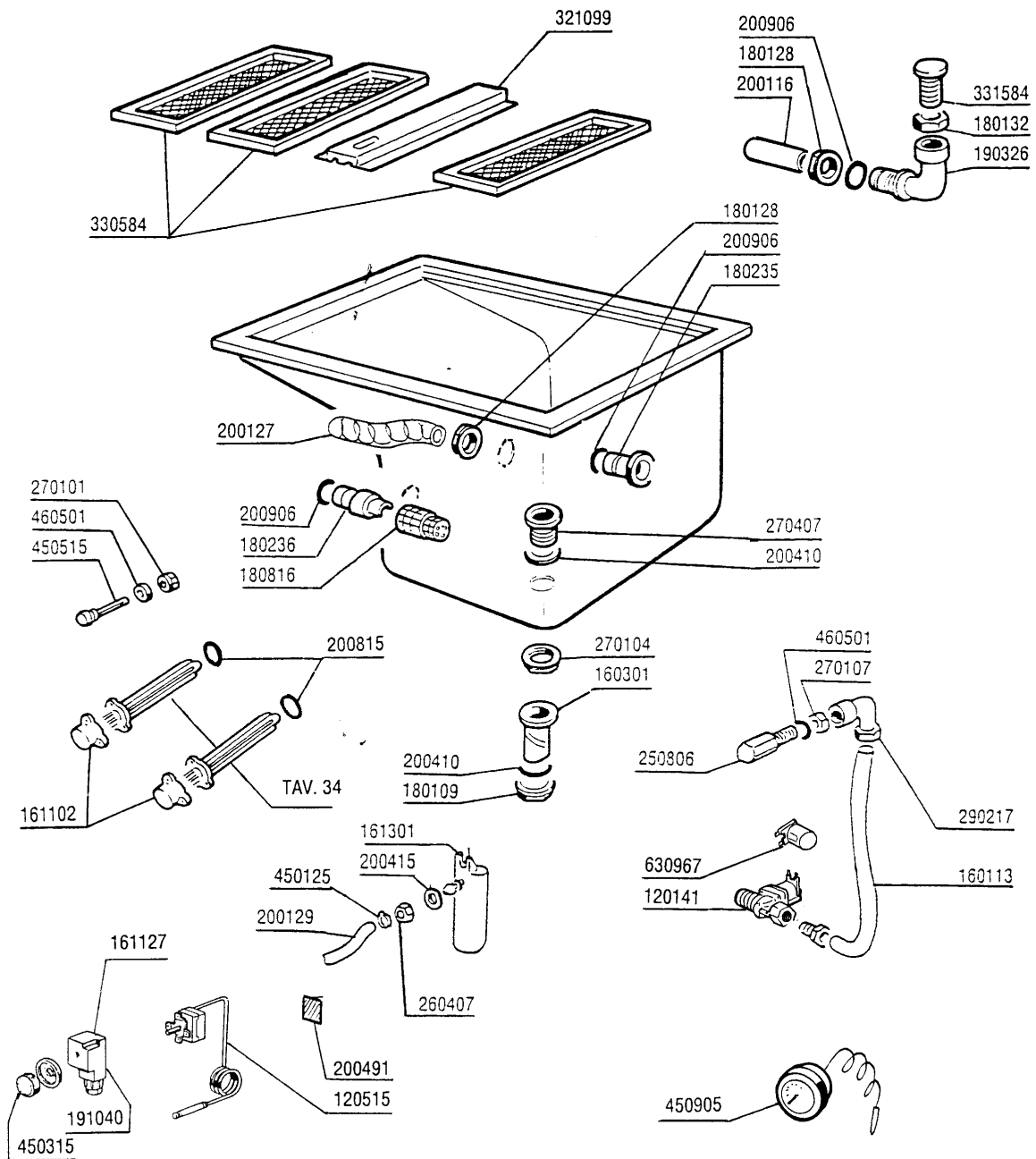

10 - Wash Tank Components 900mm

CODE	DESCRIPTION
120141	SOLE.N.VALVE METAL.328000 D.1/2
120515	THERMOSTAT 0-90°C
160113	TUBE IN POL. RETIC. 12 EST
160301	DRAIN OUTLET 1 1/2 C-S-N
161102	ELEMENT COVER MOPL.
161127	BOX FOR THERMOSTAT
161301	AIR TRAP F2 C34-F45
180109	LOCK NUT 1 1/2"
180128	RING NUT 65,4 C140 C85
180132	LOCK NUT 2" FOR OVERFLOW AC-AC
180235	PUMP SUCTION C85-140
180236	PUMP SUCTION FOR AC-ACR-C155
180816	STRAINER OF INLET PUMP AC-ACR
190326	ELBOW FOR OVERFLOW AC-ACR
191040	FRAME F.THERMOSTAT KNOB
200116	RUBBER HOSE 60X70
200127	PVC HOSE D.35
200129	HOSE 5X11 FOR PRESSURE SWITCH
200410	DRAIN OUTL.WASH.1 1/2"65X47X2
200415	AIR TRAP GASKET -F2 18,5X10X3
200491	BACK GASKET OF THERMOSTAT BOX
200815	O-RING F. HEAT.ELEM.
200906	GASKET D.92X66X2
250806	TANK FILL HOSE CLAMP - AC/ACR
260407	STAINLESS STEEL NUTS D10 UNI 5
270101	HEXAGON LOCK NUT 1/2"
270104	LOCK NUT 1" 1/2
270107	BRASS LOCK NUT 3/8" FL803
270407	TANK DRAIN OUTLET ACR
290217	HOSE CLAMP ELBOW 12X3/8" TYPE
321099	SUPPORT
330584	WASH FILTER ACR
331584	ELBOW FOR AC-ACR OVERFLOW
450125	ELASTIC CLAMP D. 10,4X9,8
450315	KNOB F. THERMOSTAT 90°
450515	STAINL.ST.SHIELD FOR 1 THERMOS
450905	CAPIL.THERMOMETER D.52 1,5M
460501	GASKET 24X17X2
630967	COIL V24/50HZ E/V 328002

11 - Sanitizing system

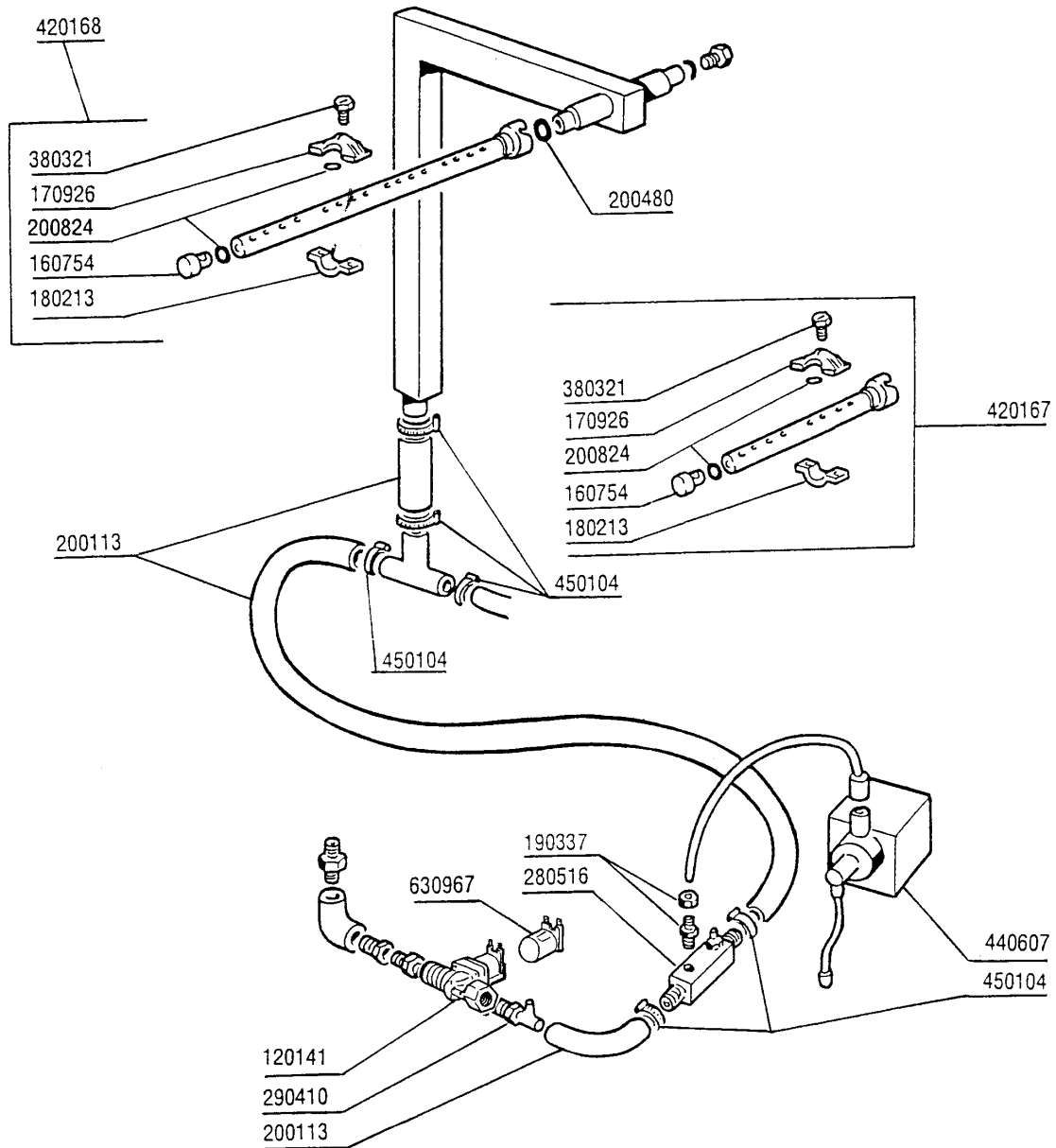

11 - Sanitizing system

CODE	DESCRIPTION
120141	SOLE.N.VALVE METAL.328000 D.1/2
160754	PLUG FOR RINSE ARMS SE NE
170926	RINSE JET HOLDER S-SE-NE
180213	FLANGE F.JET LOCKING F2-C34
190337	CONNECTION 1/4" X 1/8"
200113	RUBBER HOSE 12 X 22
200480	GASKET F. RINSE CONNECT.
200824	O-RING 1,78X12,42X15,98
280516	CONNECTION 14M X 2
290410	NIPPLE 1/2"
380321	RINSE JETS OV 1/8" 303 40LT 80
420167	WASH ARM FOR SELF CLEANING
420168	WASH ARM FOR SELF CLEANING
440607	INJECTOR 24V 50HZ
450104	CLAMP FE ZN H=12,5 15-24
630967	COIL V24/50HZ E/V 328002

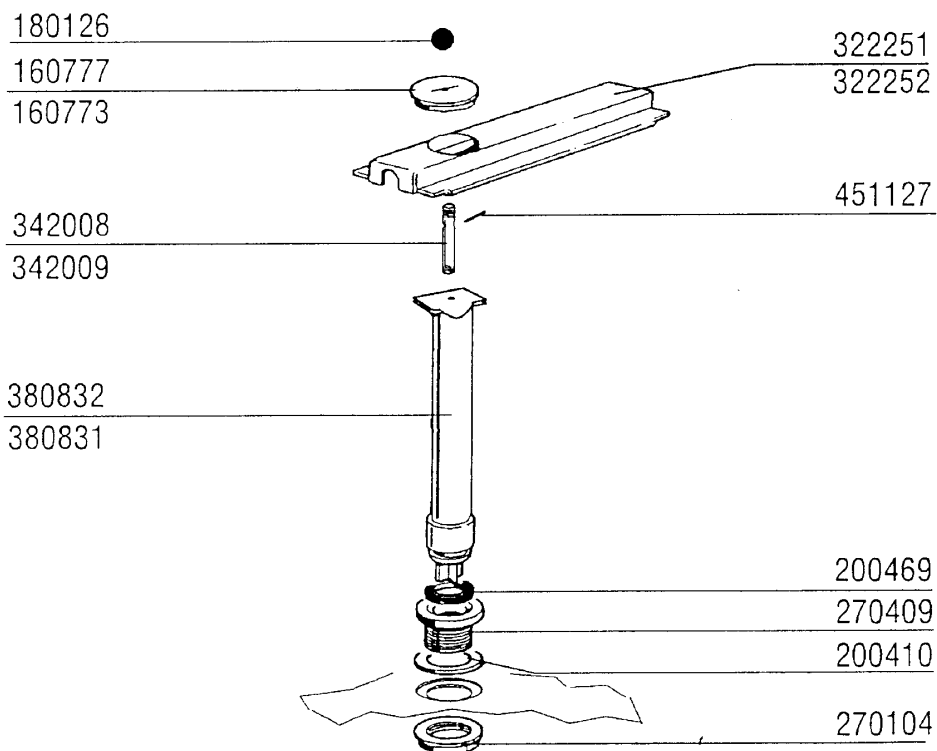
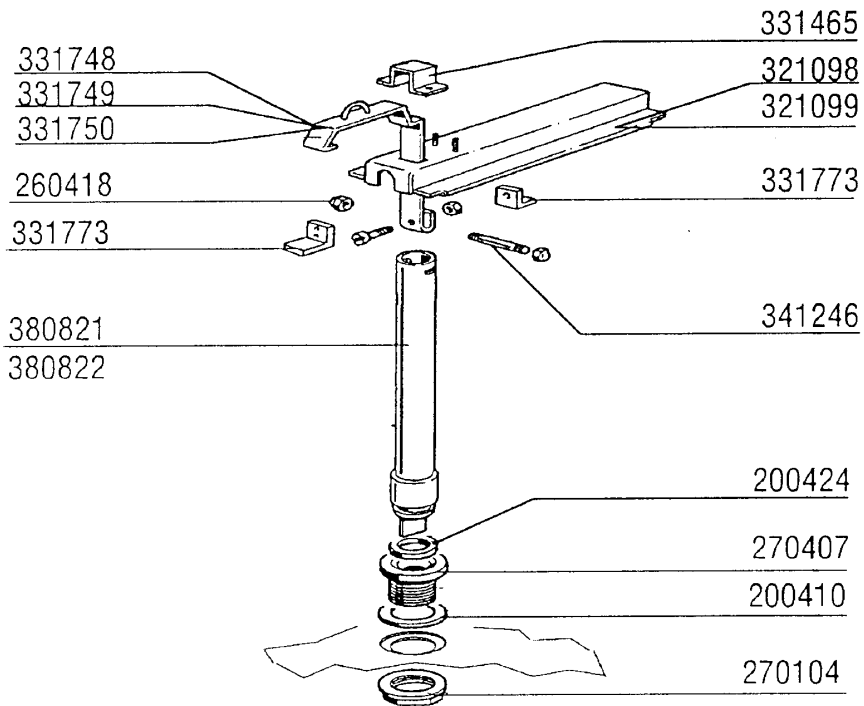

01-96

12 - Drain Parts

CODE	DESCRIPTION
160773	PLUG FOR OVERFLOW PIPE
160777	OVERFLOW PIPE PLUG PREWASH AC-
180126	HANDLE F.OVERFLOW PIPE SNL
200410	DRAIN OUTL.WASH.1 1/2"65X47X2
200424	O RINGS WASH/PRE-WASH ARMS
200469	STAND PIPE O RING 45X35,5X7
260418	SELF-LOCKING NUT M4
270104	LOCK NUT 1" 1/2
270407	TANK DRAIN OUTLET ACR
270409	DRAIN OUTLET AC-ACR
321098	SUPPORT
321099	SUPPORT
322251	SUPPORT
322252	SUPPORT
331465	BRACKET FOR UNLOADING
331748	PREWASH OVERFLOW LEVER FOR AC-
331749	WASH OVERFLOW LEVER FOR AC-ACR
331750	WASH OVERFLOW LEVER-ACR CORNER
331773	BRACKET
341246	SHAFT FOR AC-ACR OVERFLOW
342008	OVERFLOW SPACER PREWASH TANK A
342009	OVERFLOW SPACER WASH TANK AC-A
380821	OVERFLOW PIPE WASH TANK ACR
380822	OVERFLOW PIPE PREWASH TANK ACR
380831	OVERFLOW PIPE PREWASH TANK AC-
380832	OVERFLOW PIPE WASH TANK AC-ACR
451127	ELASTIC PIN 5X34

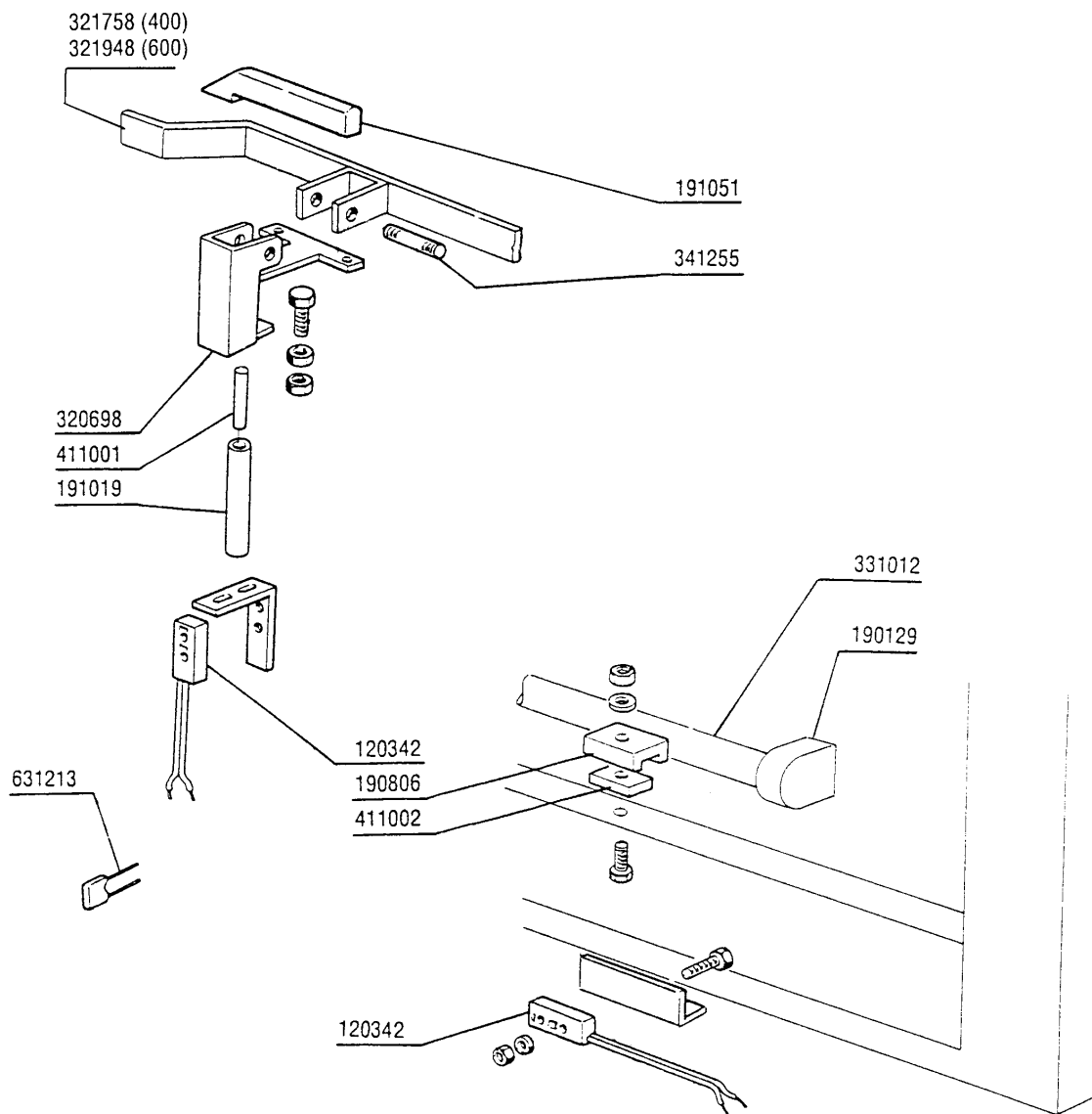

13 - Economiser

CODE	DESCRIPTION
120342	DOR MAGNETIC SWITCH
190129	HANDLE SUPPORT SE NE GREY
190806	MAGNET HOUSING
191019	MAGNET HOUSING S90 MOPL.-S.N.L
191051	SLIDING PAD SE SNL ECONOMIZER
320698	LEVER FOR ECONOMIZER SE SNL
321758	GUIDE
321948	GUIDE
331012	HANDLE 412 MM DOOR SE NE G115
341255	PIN FOR ECONOMIZER SE SNL
411001	PERMANENT MAGNET 8X40
411002	PERMANENT MAGNET 24X12
631213	CAPACITOR 0,1MF

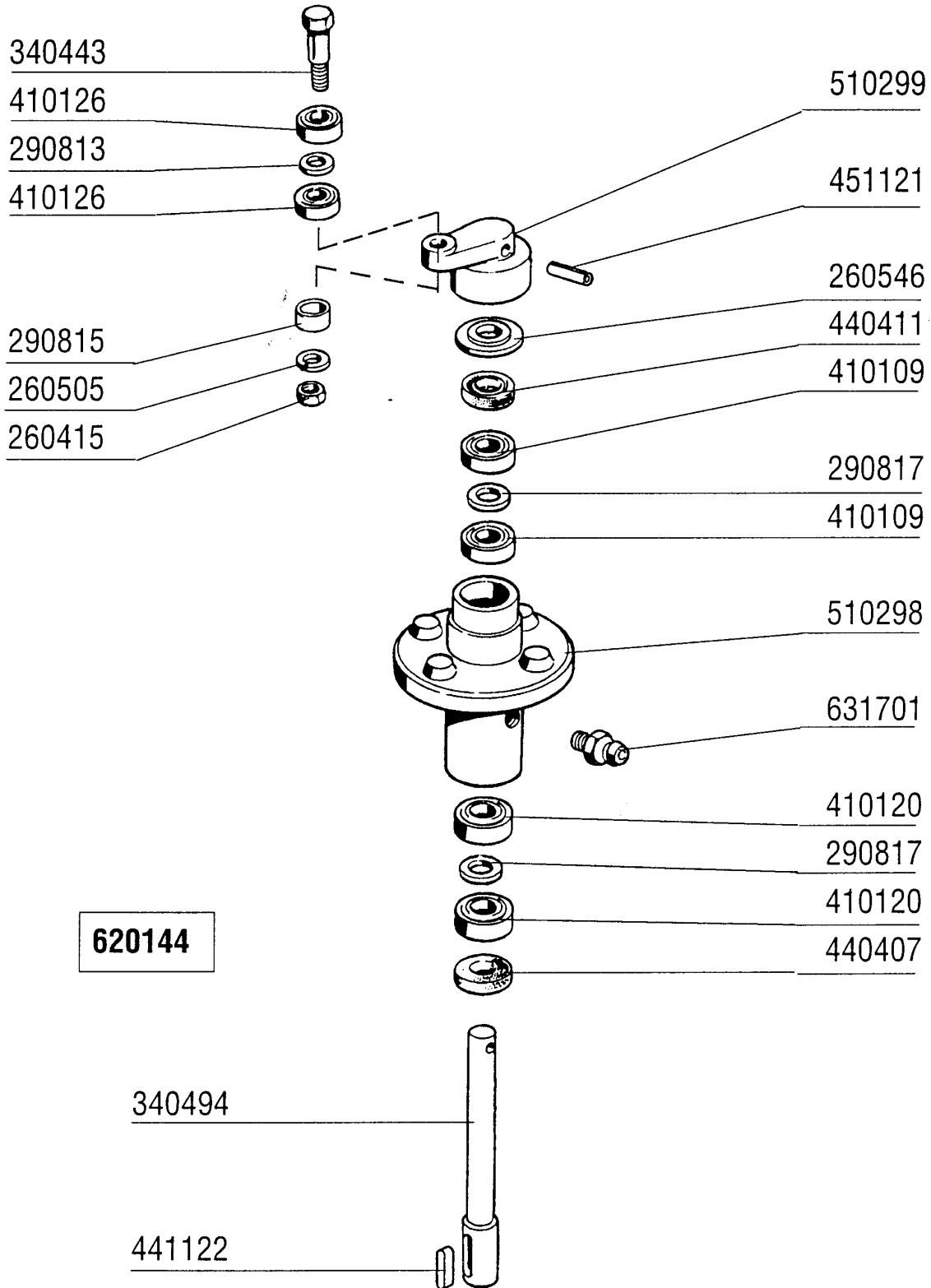

14 - Drive unit

CODE	DESCRIPTION
260415	STAINLESS STEEL SELF-LOCKING N
260505	STAINL.STEEL FLAT WASHER D8
260546	SLIDING WASHER STAINLESS STEEL
290813	PACKING PIECES BRASS S-F2
290815	DISTANCE PIECE S3Ø BRASS
290817	BRASS DISTANCE PIECE 24X14
340443	CRANK SHOULDER PIN
340494	DRIVE SHAFT S 3Ø
410109	BEARINGS 17X40X12 6203
410120	BALL BEARING 17X35X10
410126	BEARING 6201-2RS Z15
440407	SEAL MIM 20X35X7
440411	SEAL 17X40X7
441122	DRIVE SHAFT KEY 6X6X25 UNI 660
451121	ELAST.ROLL PINS 6X30
510298	DRIVE HOUSING S 3Ø
510299	NICKELPLATED BRASS DRIVE CRANK
620144	DRIVE ASSEMBLY
631701	GREASE NIPPLE 9003

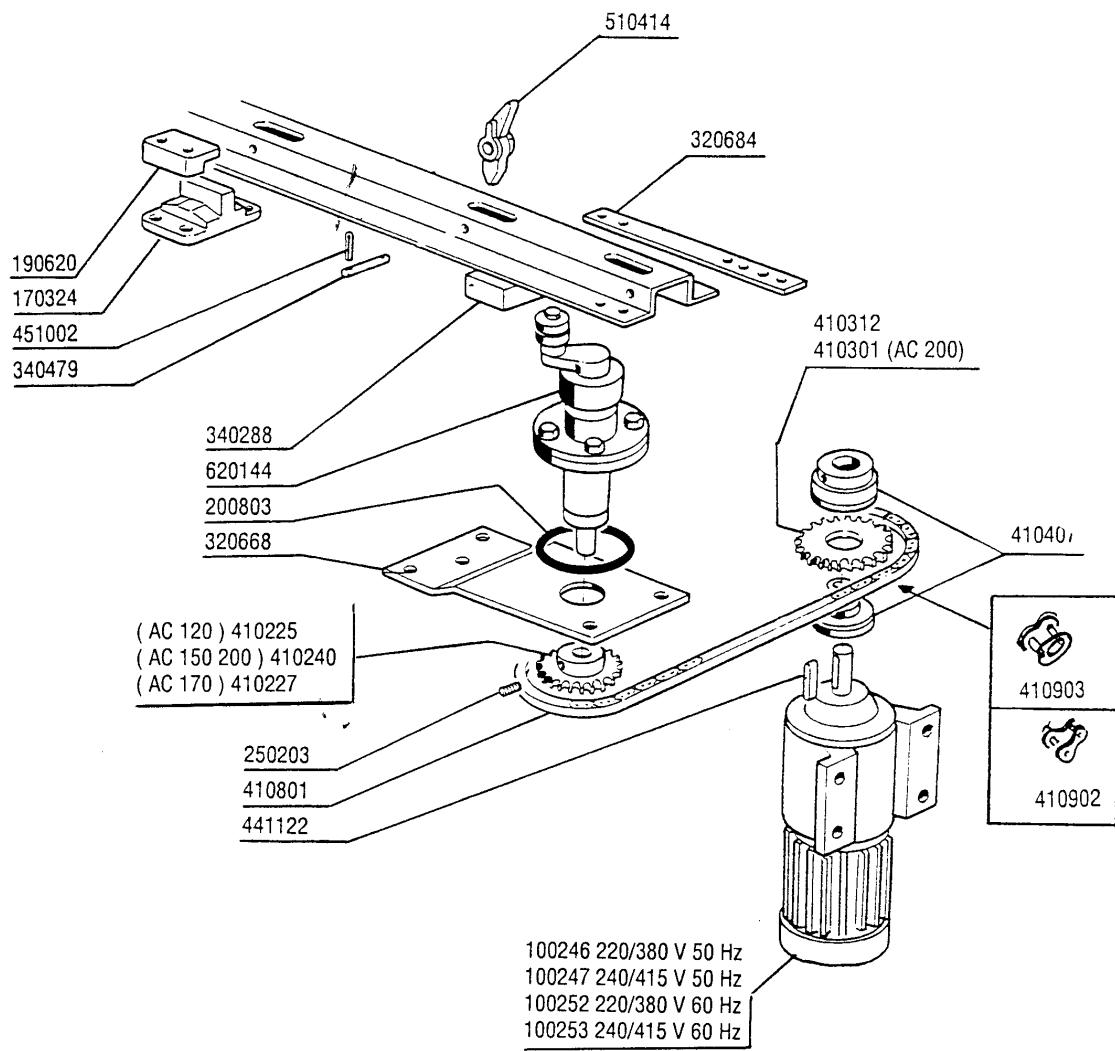

15 - Drive unit

CODE	DESCRIPTION
100246	DRIVE KW 0,1-0,15 380/3
100247	DRIVE KW 0,1-0,15 415/3 SK01-7
100252	DRIVE MOTOR 0,1-0,15KW 380/60
100253	DRIVE MOTOR 0,1-0,15KW 440/60
170324	GUIDE SUPPORT SE-S2200-290
190620	CLAMPING PIECES S 3
200803	OR GASKET 3,53X98,02X105,08
250203	GRUB SCREW 8X12
320668	PLATE
320684	BRACKET
340288	CHANNEL F.DRIVE BEARING S3Ø-SE
340479	PAWL PINS SNL-SE
410225	TURNUED PINION Z22-1/2"-D.20
410227	TURNUED PINION Z16-1/2"-D.20
410240	TURNUED PINION Z17-1/2"-D.20
410301	CROWN DISCS 28T PITCH 1/2"
410312	CROWN DISCS 22T
410407	TORQUE LIMITER LC 1
410801	DRIVE CHAIN 1/2" N-S
410902	FALSE CHAIN LINK 1/2"
410903	CHAIN JOINT 1/2"
441122	DRIVE SHAFT KEY 6X6X25 UNI 660
451002	COTTER PIN STAINL.ST. D2X12
510414	NICKEL-PLATED PAWL SNL-SE
620144	DRIVE ASSEMBLY

16 - Side Loading Table

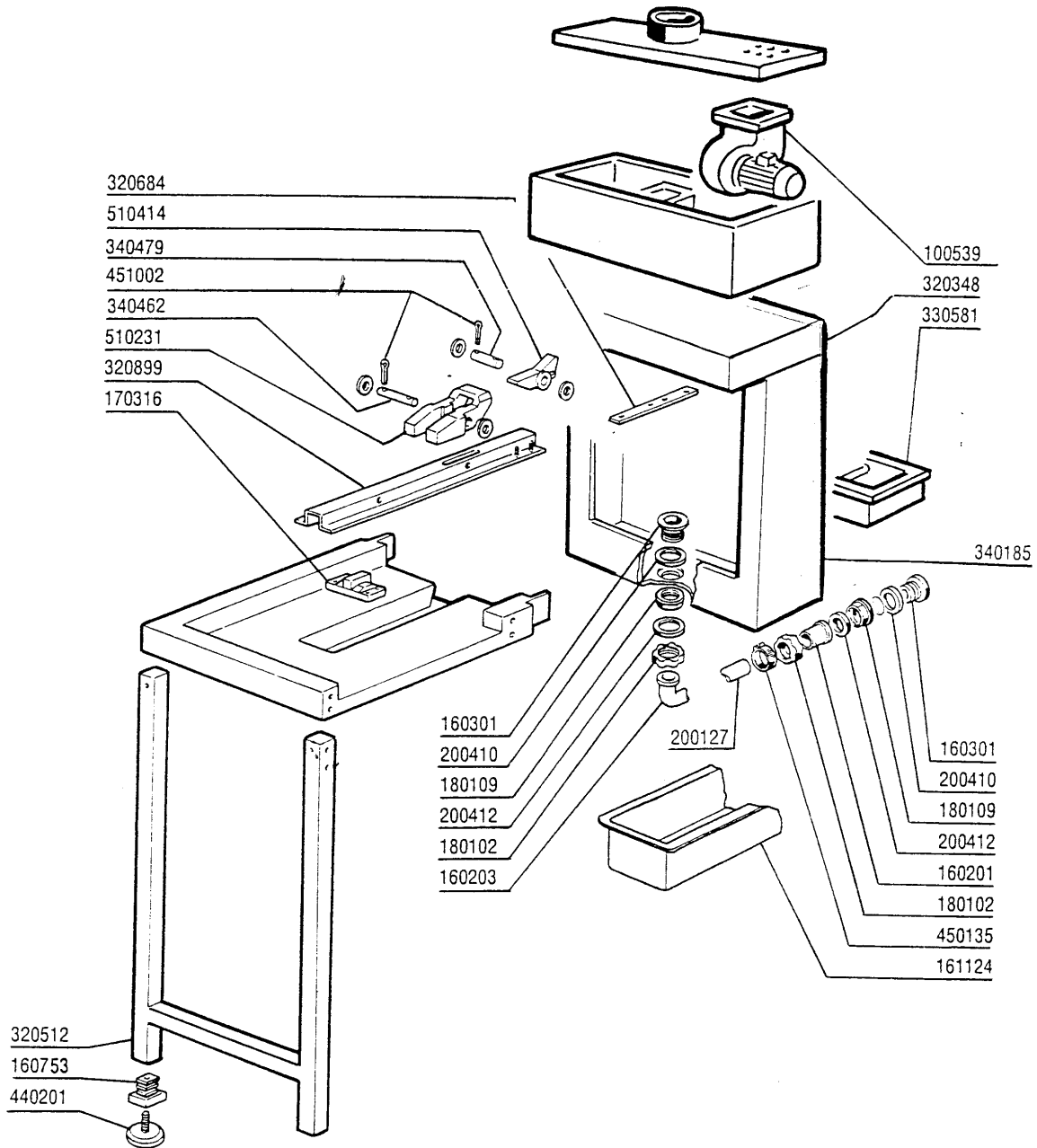

16 - Side Loading Table

CODE	DESCRIPTION
100539	EXHAUST FAN F.SPLASH GUARD 220
160201	ELBOW F.TANK INLET MOPLN
160203	ELBOW 1"1/2 N-S-F-C /DRAIN
160301	DRAIN OUTLET 1"1/2 C-S-N
160753	PLUG 40X40X1
161124	DRYING OUTLET HOSE PROTECTION
170316	SUPPORT OF PAWL BAR GUIDE CO
180102	DRAIN PIPE NUT 1"1/2 F45-55
180109	LOCK NUT 1 1/2"
200127	PVC HOSE D.35
200410	DRAIN OUTL.WASH.1 1/2"65X47X2
200412	GASKET DRAIN 11/2" 45X33X3
320348	BASE TOP FOR SPLASH HOOD
320512	TABLES LEG
320684	BRACKET
320899	GUIDE
330581	DRAWER FILTER EXTENTION HOODS
340185	HOOD
340462	SHORT TRAY CARRIER PIN GM-S290
340479	PAWL PINS SNL-SE
440201	RUBBER FOOT D.60X10
450135	CLAMP FE ZN. 44-56 H=12,2
451002	COTTER PIN STAINL.ST. D2X12
510231	PAWL /CORNER LOAD.
510414	NICKEL-PLATED PAWL SNL-SE

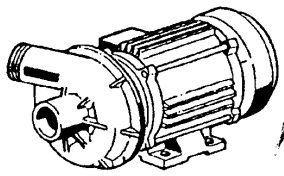

100674 (220/380 V 50 Hz)
(240/415 V 50 Hz)

100690 (220/380 V 60 Hz)
(240/415 V 60 Hz)

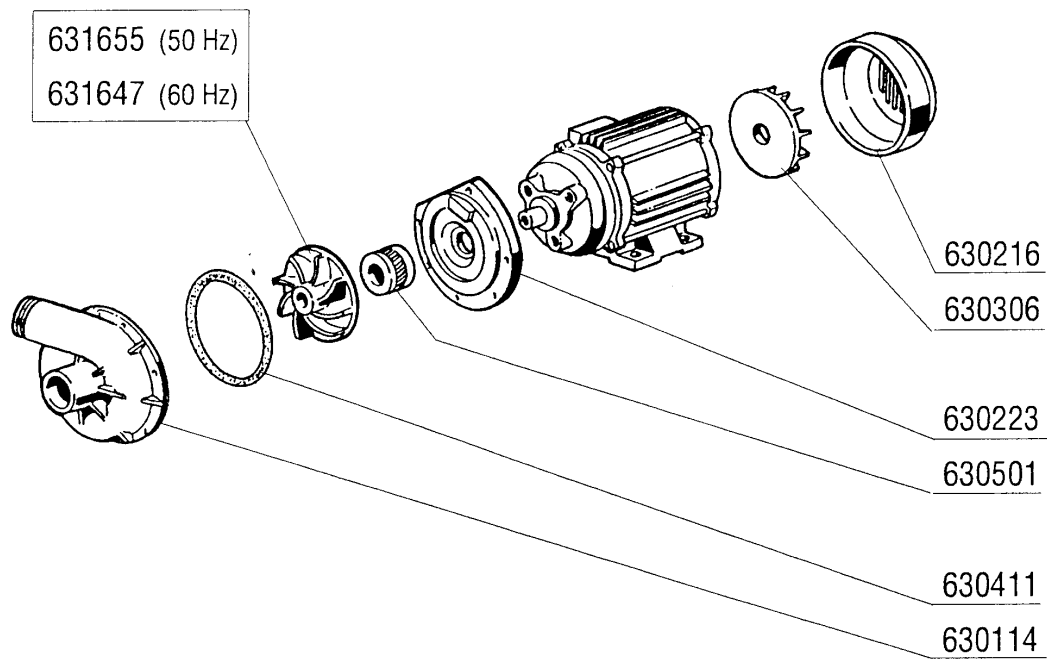

17 - Pump 3HP

CODE	DESCRIPTION
100674	PUMP HP 3 V.220-415-50HZ-1205
100690	PUMP 2,7HP 220/380 60HZ 1205
630114	VOLUTE FI HP2-2,7-3-3,2
630216	FAN HOUSING FIR HP 2-3
630223	BACK PLATE PUMP HP2-3-3,2
630306	PUMP FAN IMPELLOR FI HP.2-3
630411	O-RING PUMP FI HP 2-2,7
630501	SEAL FOR PUMP HP 2-3-3,2
631647	IMPELLER D.100-60HZ-1204/5
631655	SEE 631620

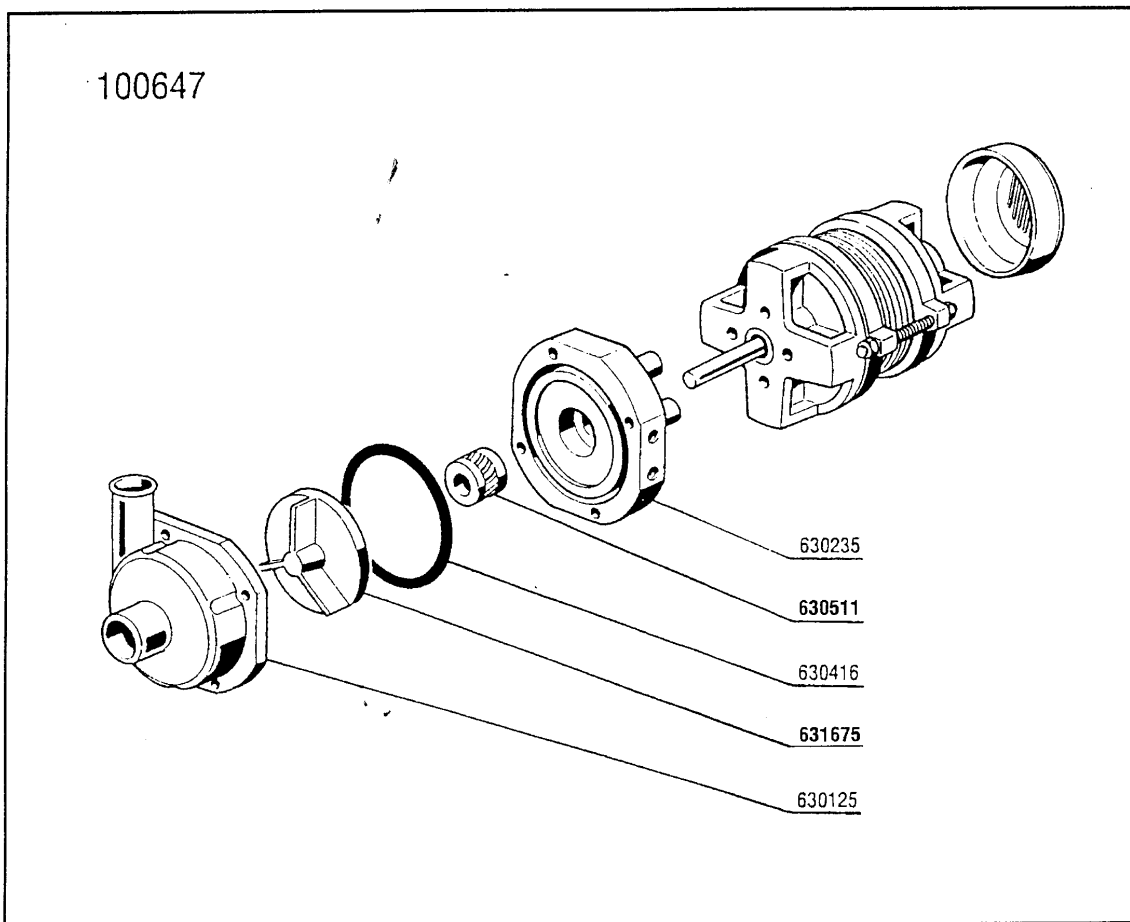

18 - Ecorinse Pump

CODE	DESCRIPTION
100647	PUMP HP 0,20 220/240/3 4226
630125	VOLUTE 0,12/0,3(2212-29)
630235	PUMP COVER 0,12/0,3 2212-19
630416	OR FOR VOLUTE 0,12/0,3
630511	PUMP SEAL HP 0,10 82
631675	ST/ST PUMP IMPELLER 0,2HP 2226

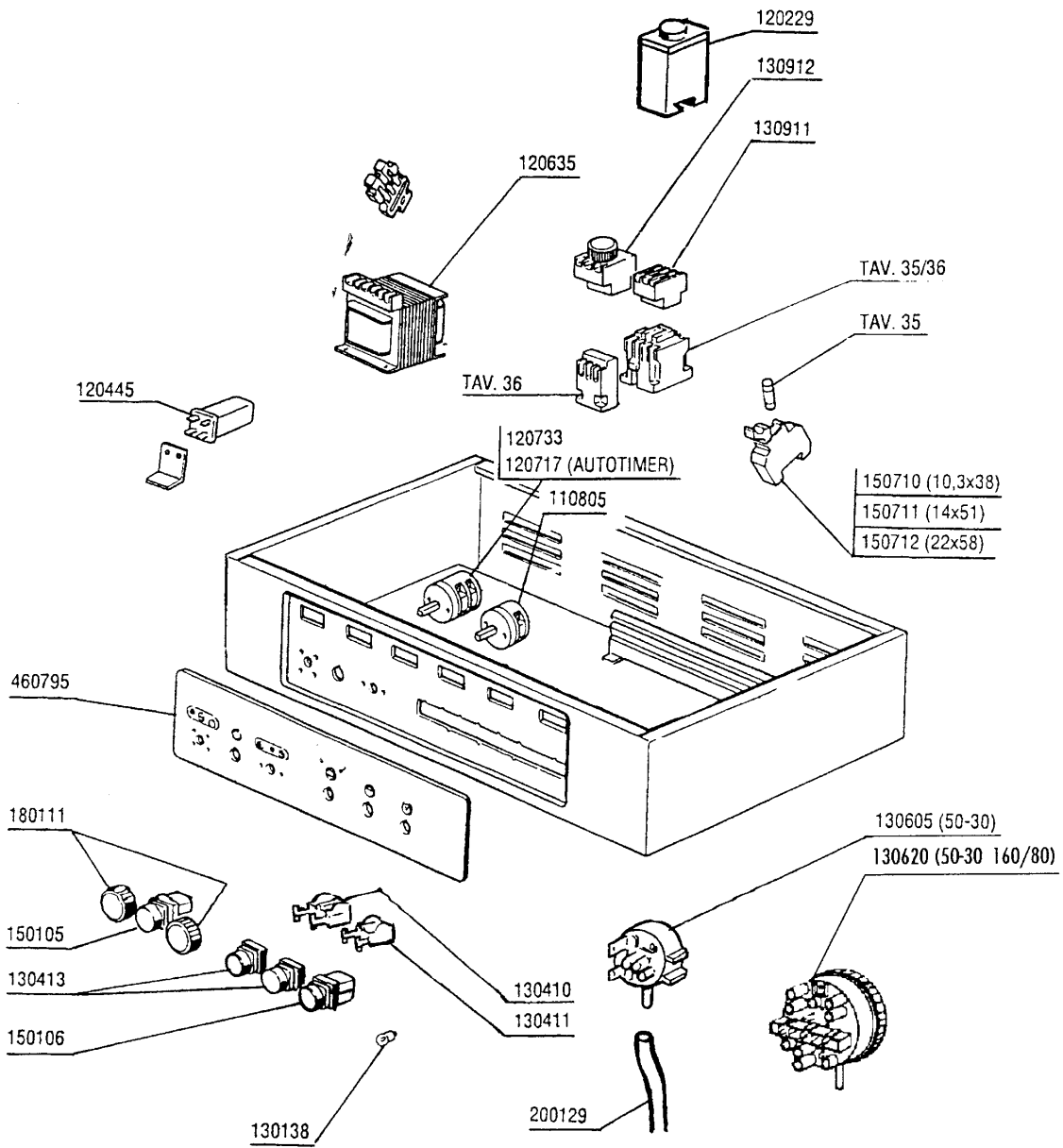

19 - Control Box

CODE	DESCRIPTION
110805	SWITCH THREEPOLE
120229	ELECTR.TIMER 24V AUTOTIMER S-S
120445	AUXILIARY RELAY S.B2/3 24V
120635	TRANSFORMER 400VA220-240-380-4
120717	SWITCH 25 AMP FIVE-POLE S-SE A
120733	4-POLE SWITCH 25A 500V
130138	LIGHT WITH BAYONET COUPLING 3W
130410	STOP CONTACT F40 CN RED
130411	START CONTACT YELLOW
130413	GREEN PUSH BUTTON
130605	PRESSURE SWITCH 50-30 1 LEVEL
130620	PRESSURE SWITCH 3 LEVEL 50-30/
130911	CONTACT LA1 D40 A65
130912	TIMER CONTACT 0,1/30SEC. LA3D2
150105	LAMP RED D.22X5
150106	LAMP GREEN 22X5
150710	FUSE CARRIER 10,3X38 ART.21401
150711	FUSE CARRIER 14X51 ART.21501
150712	FUSE CARRIER 22X58 ART.21601
180111	BLACK KNOB
200129	HOSE 5X11 FOR PRESSURE SWITCH
460795	PLATE AC135/150

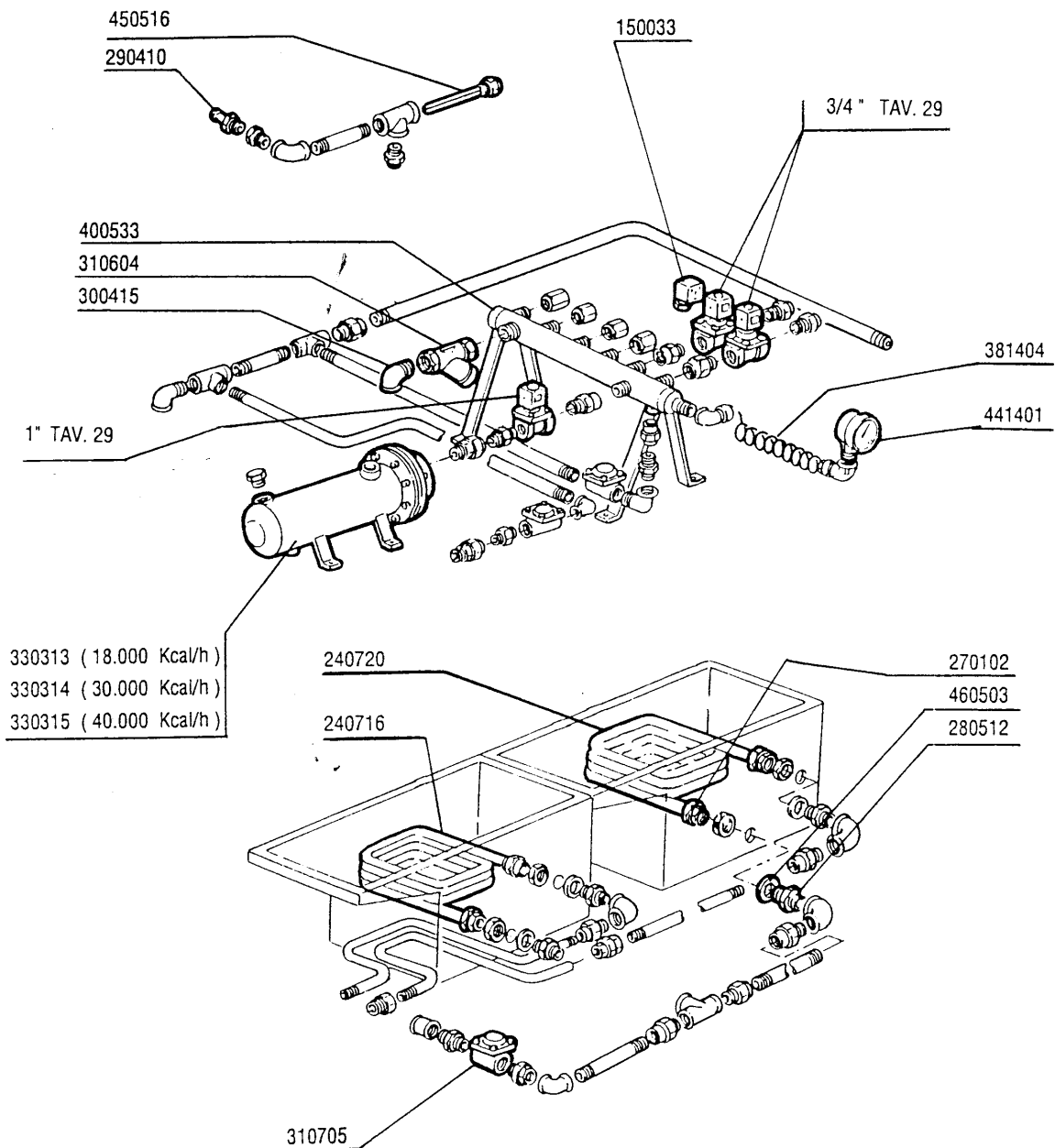

CODE	DESCRIPTION
150033	CONNEX.F.SOLEN.VALVE 182.09.N
240716	STEAM COIL G66-S3
240720	S/S STEAM COIL 12.000KCAL ACR/
270102	LOCK NUT 3/4"
280512	STEAM COIL CONNECTION
290410	NIPPLE 1/2"
300415	ELL 2" MF
310604	STRAINERS JU 2" MOD.45
310705	STEAM TRAPS MK25/3 D.1/2"
330313	STEAM BOILER 18000KCAL/H
330314	STEAM BOILER 30000 KCAL/H
330315	STEAM BOILER 40000KCAL/H
381404	HOSE STEAM GAUGE
400533	ST/ST STEAM MANIFOLD FOR NE MA
441401	PRESSURE GAUGE 60 SCALO-4CR1/4
450516	THERMOSTAT SHIELD FOR 2 TERMOS
460503	SEALING WASHER 38X27X2(3/4)

150033

120166 (1')
120165 (3/4')

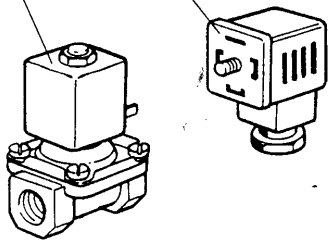

630976 (1')
630972 (3/4')

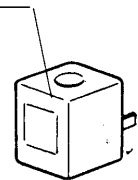

630629 (1')
630628 (3/4')

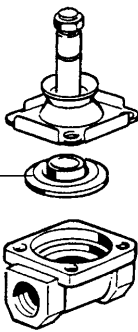

0 ÷ 2 bar

150033

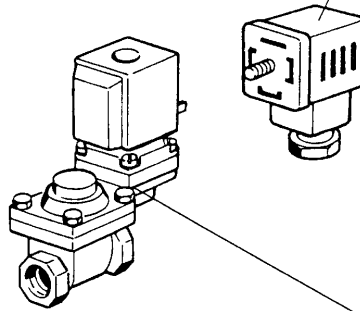

120163 (1')
120162 (3/4')

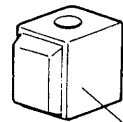

630972 (1')
630973 (3/4')

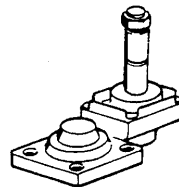

630626 (1')
630625 (3/4')

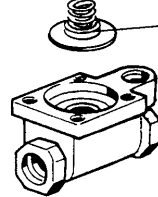

0,5 ÷ 2,5 bar

21 - Steam solenoid valve

CODE	DESCRIPTION
120162	SOLENOID VALVE L145R1Z734A 3/4
120163	SOLEN.VAL.ST.L145R1Z234A 1"24V
120165	SOLEN.VALVE ST.24V50HZ 3/4"
120166	STEAM SOLEN.VALVE 1" 24V-50
150033	CONNEC.F.SOLEN.VALVE 182.09.N
630625	KIT F.SOLEN.VALVE
630626	KIT FOR SOLENOID VALVE 145 1"
630628	KIT F.SOLEN.V.L153D1 3/4"
630629	KIT SOLENOID VALVE 1" STEAM L1
630972	COIL Z534A/V.24-L145A-3/4
630973	COIL Z614A/V.24-L145-3/4 A
630976	COIL Z114A/V24/50HZ L153-1"

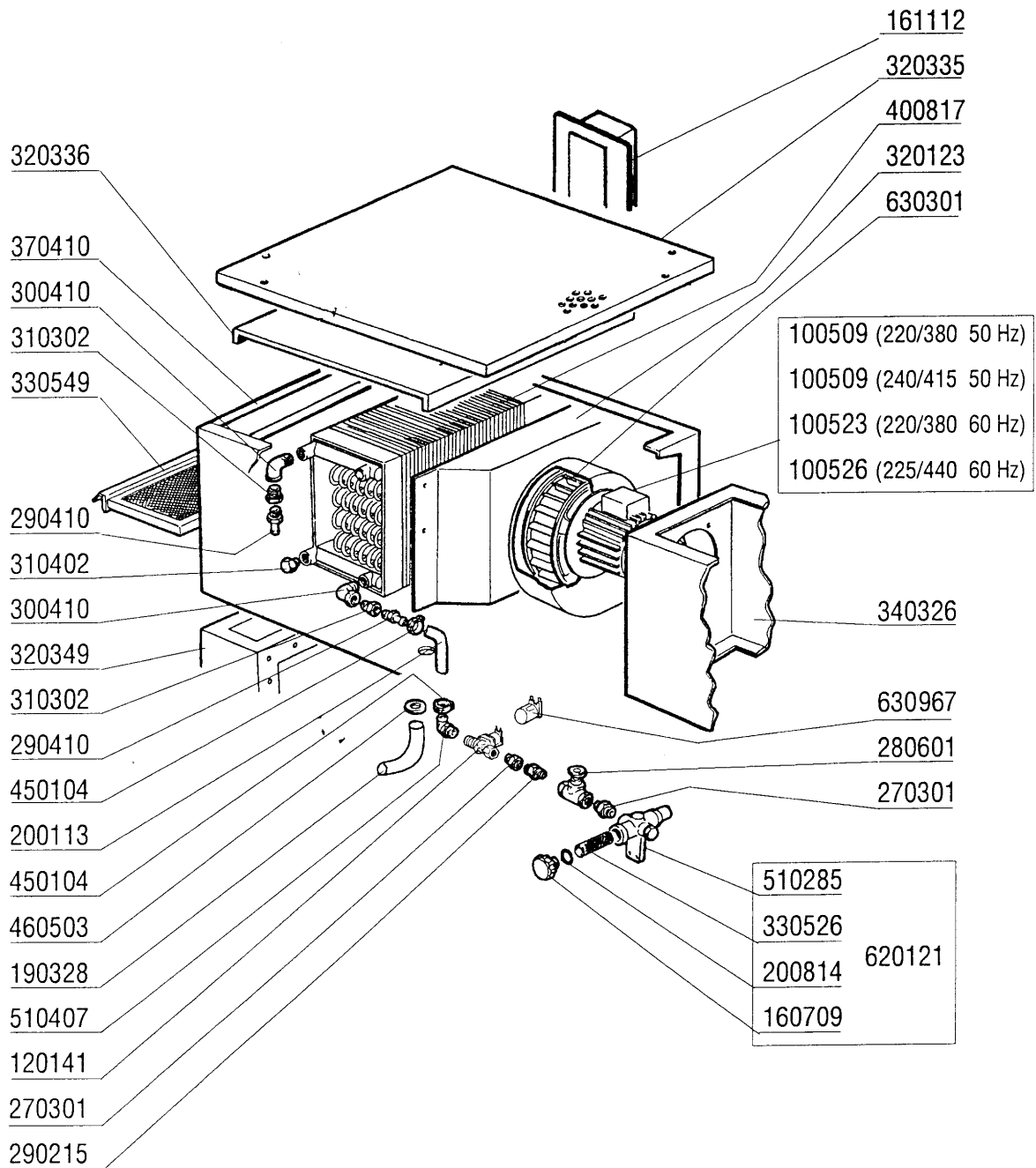

22 - Steam Condenser

CODE	DESCRIPTION
100509	FAN 0,75HP 220/415 V164/2
100523	FAN 0,75 HP 220/380V-60HZ
100526	FAN HP 0,75 255/440-60-VR184
120141	SOLEN.VALVE METAL.328000 D.1/2
160709	KNOB OF MANIFOLD F. SOLEN. VAL
161112	BACK COVER CHANNEL 300 S N
190328	DRAIN 3/4"
200113	RUBBER HOSE 12 X 22
200814	O-RING 34,52X41,58X3,53
270301	BRASS NIPPLES 1/2"
280601	GATE VALVE 1/2" BRASS
290215	1/2"BSP M/F UNION BRASS
290410	NIPPLE 1/2"
300410	ELL 3/4" MF
310302	NIPPLE 3/4"-1/2"
310402	PLUG 3/4"
320123	VORTEX BREAKER F.STEAM CONDENS
320335	TOP PANEL FOR STEAM CONDENSER
320336	TOP PANEL FOR STEAM CONDENSER
320349	TOP FOR SPLASH HOOD WITH STEAM
330526	FILTERS 22X28 SOLENOID V.MANIF
330549	CONDENSATE UNIT FILTER
340326	PANEL
370410	CONDENSER MODULE
400817	BATTERY FOR STEAM CONDENSER +
450104	CLAMP FE ZN H=12,5 15-24
460503	SEALING WASHER 38X27X2(3/4)
510285	SOLENOID VALVE MANIFOLD - BRAS
510407	NIPPLE FOR BOILER N S
620121	TWIN SOLENOID VALVE MANIFOLD
630301	FAN IMPELLOR FOR 100509
630967	COIL V24/50HZ E/V 328002

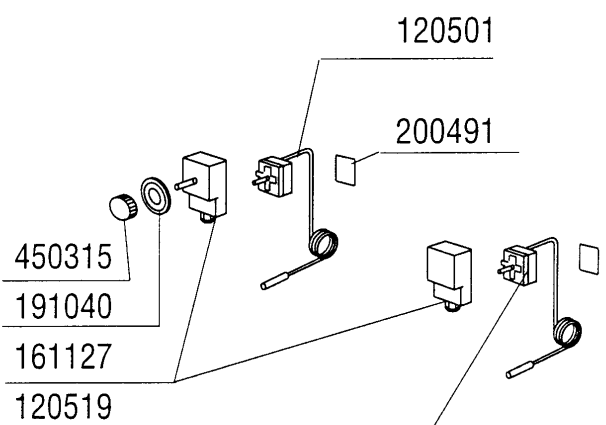
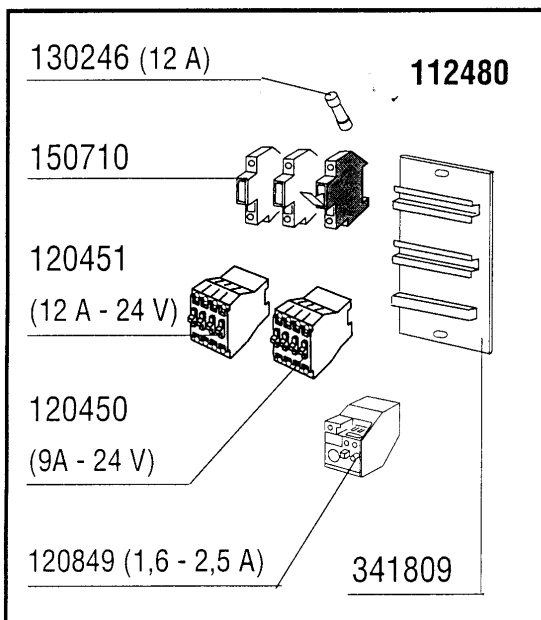
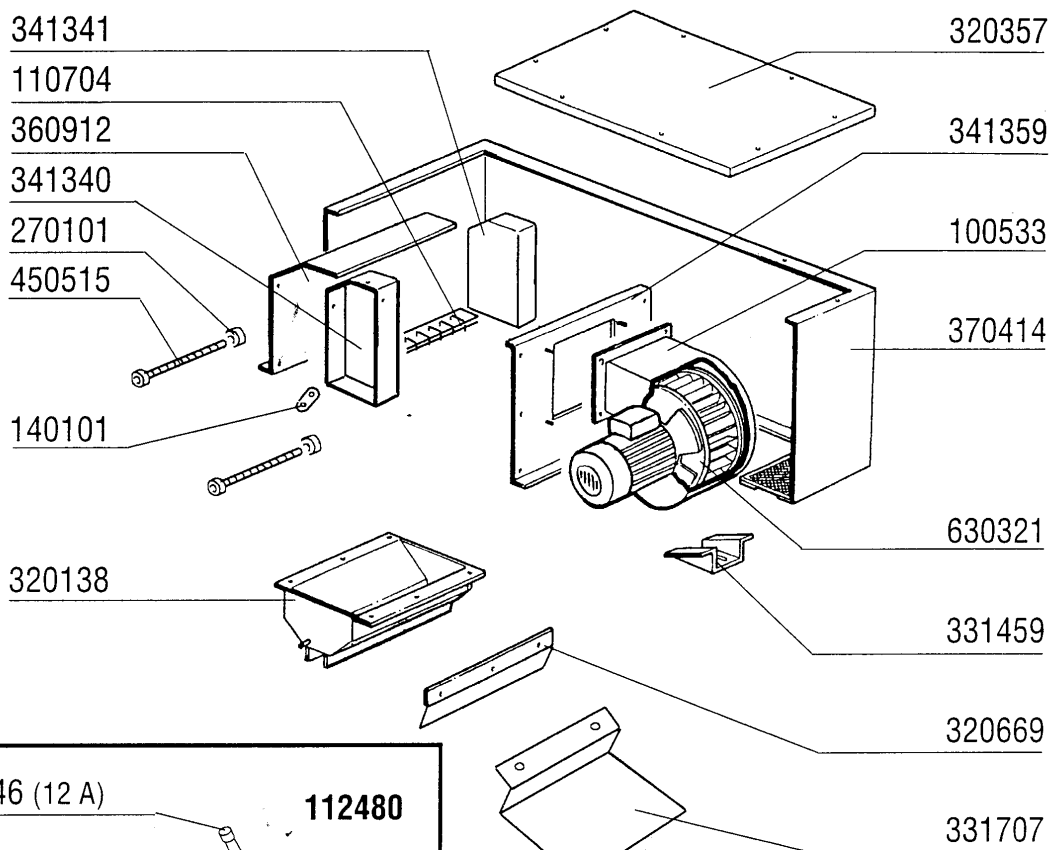

23 - Blower Dryer

CODE	DESCRIPTION
100533	FAN HP 1 220-240-380-415V VRP2
110704	HEAT.ELEMENT/DRYING 1000W 220V
112480	WIRING DRYER "AC91/101/95/105"
120450	CONTACTOR 9A 24V 4KW
120451	CONTACTOR 12A 24V 5,5KW
120501	THERMOSTAT 30/90°C
120519	SECURITY THERMOSTAT 95-125°C
120849	OVERLOAD RELAY 1,6/2,5A
130246	FUSE 10.3X38 12A GF13312
140101	BRASS CONNECT. PLATE HEAT.ELEM
150710	FUSE CARRIER 10,3X38 ART.21401
161127	BOX FOR THERMOSTAT
191040	FRAME F.THERMOSTAT KNOB
200491	BACK GASKET OF THERMOSTAT BOX
270101	HEXAGON LOCK NUT 1/2"
320138	DEFLECTOR F. DRYER
320357	DRYER COVER
320669	FIXING PLATE
331459	BRACKET FOR DRYING VENTILATOR
331707	BRACKET
341340	LEFT SUPPORT
341341	RIGHT SUPPORT
341359	FAN SUPPORT
341809	DRYER SUPPORT AC
360912	BACK PANEL
370414	DRYING MODULE
450315	KNOB F. THERMOSTAT 90°C
450515	STAINL.ST.SHIELD FOR 1 THERMOS
630321	FAN IMPELLOR FOR C 100533 1HP

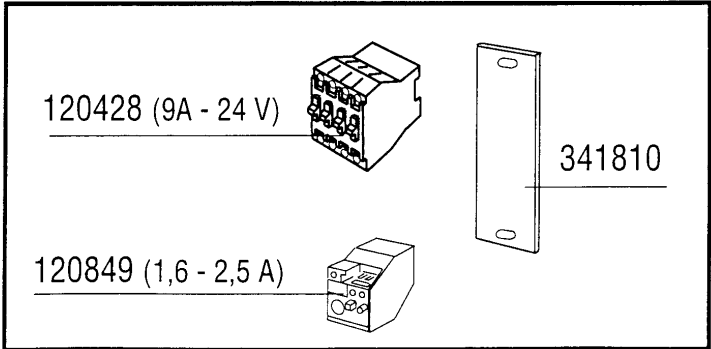
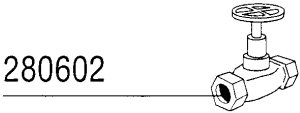
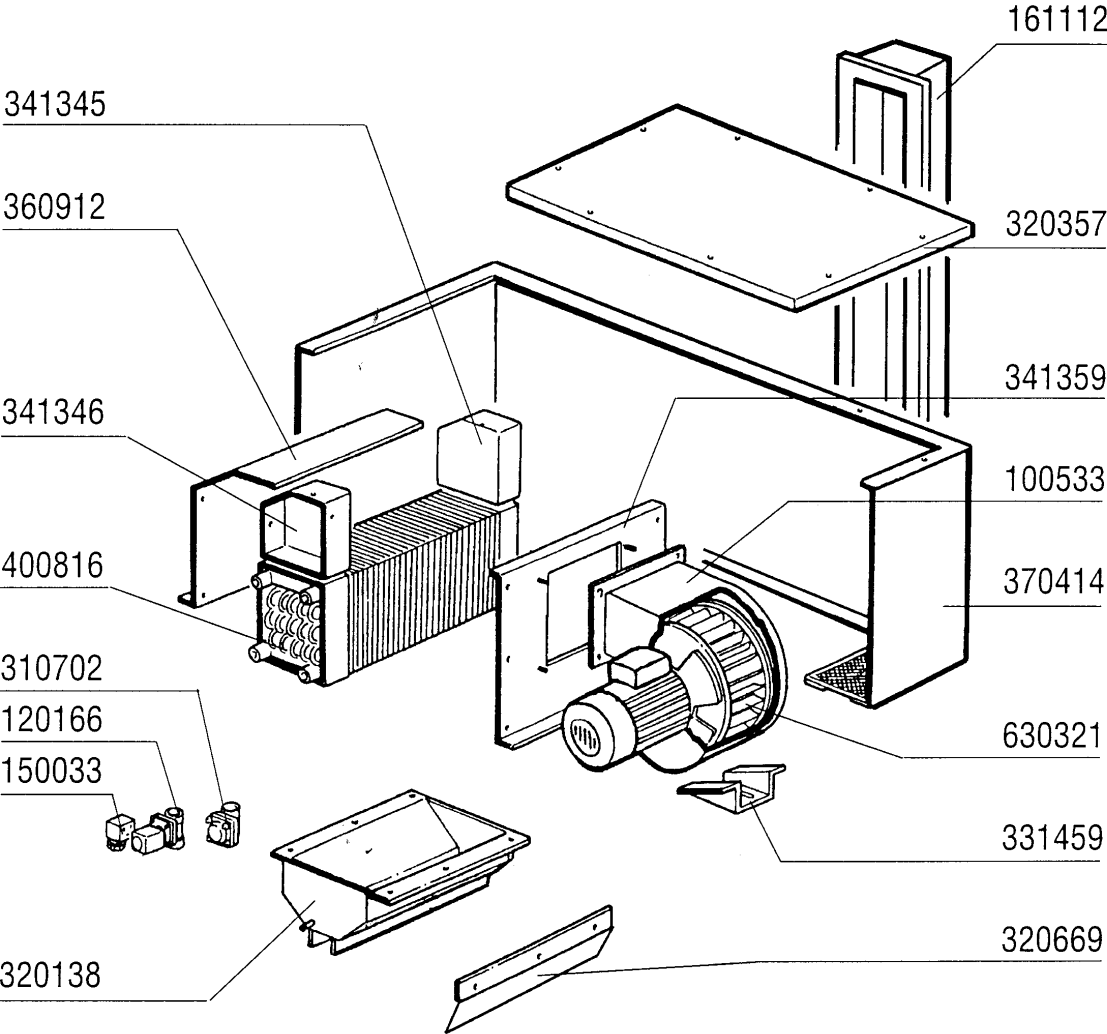

24 - Steam Blower Dryer

CODE	DESCRIPTION
100533	FAN HP 1 220-240-380-415V VRP2
120166	STEAM SOLEN.VALVE 1" 24V-50
120428	CONTACTOR 9A 24V 50HZ
120849	OVERLOAD RELAY 1,6/2,5A
150033	CONNEC.F.SOLEN.VALVE 182.09.N
161112	BACK COVER CHANNEL 300 S N
280602	GATE VALVE 3/4" BRASS
310702	STEAM TRAP 1/2" MK 25/3
320138	DEFLECTOR F. DRYER
320357	DRYER COVER
320669	FIXING PLATE
331459	BRACKET FOR DRYING VENTILATOR
341345	RIGHT PANEL
341346	LEFT PANEL
341359	FAN SUPPORT
341810	STEAM CONDENSER SUPPORT FOR AC
360912	BACK PANEL
370414	DRYING MODULE
400816	BATTERY FOR DRYING (6KW) S
630321	FAN IMPELLOR FOR C 100533 1HP

25 - Door counterbalance

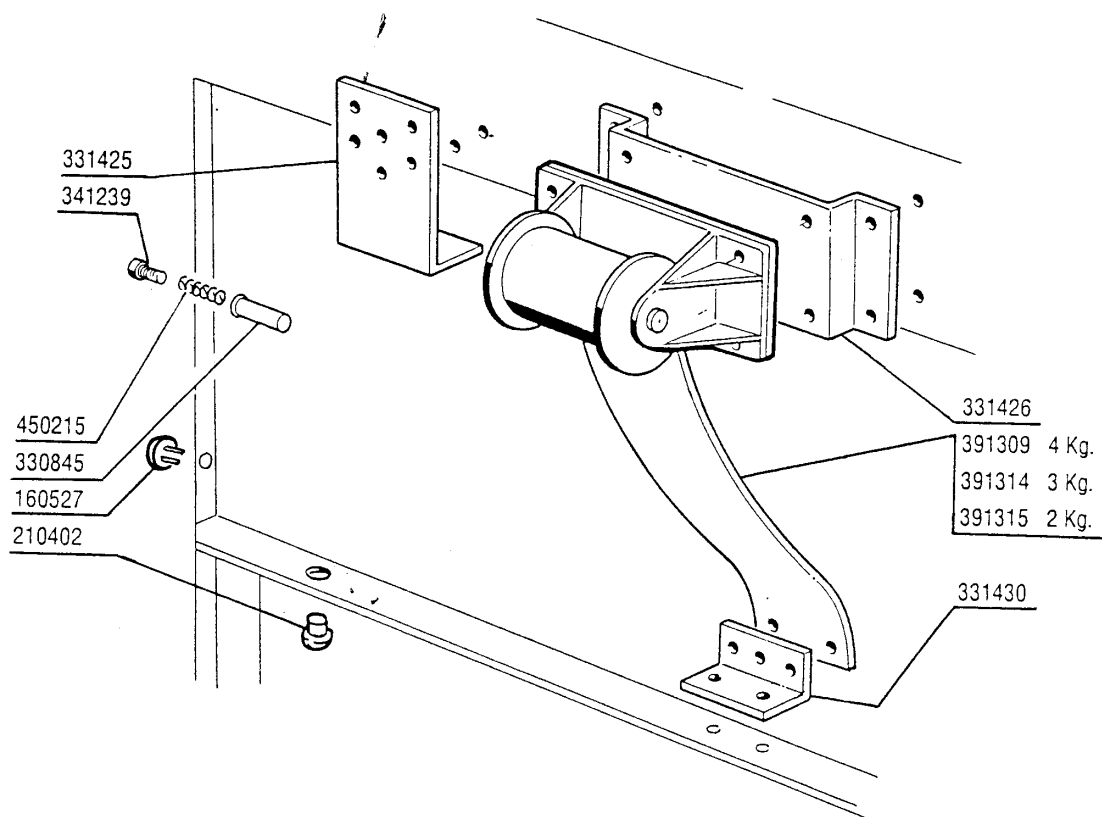

25 - Door counterbalance

CODE	DESCRIPTION
160527	PLUG 14,5X2X8
210402	PAD FOR DOOR 15-149
330845	BUSH FOR DOOR FRICTION RAIL N
331425	DOOR CATCH BRACKET SE
331426	BRACKET F. HOOD SPRING FIXING
331430	BRACKET FOR DOOR SPRING
341239	PIN F.DOOR FRICTION RAIL N S
391309	DOOR SPRING 4KG - 40MM
391314	DOOR SPRING 3KG - 40MM
391315	DOOR SPRING 2,5KG - 40MM
450215	SPRING F.SWITCH ROD R/B41-11-2

26 - Heating Elements

MOD.	Prelavaggio - Prelavage Prewash - Vorwaschzone Prelavado 600	Prelavaggio - Prelavage Prewash - Vorwaschzone Prelavado 900	1°lavaggio - 1° lavage 1° wash - 1. Waschzone 1° lavado 900	2°lavaggio - 2° lavage 2° wash - 2. Waschzone 2° lavado 600	2°lavaggio - 2° lavage 2° wash - 2. Waschzone 2° lavado 900	Ecorinse	Risciacquo - Rinçage Rinse - Nachspülung Aclarado
AC 90			1 x 9 kw				1 x 8 kw 1 x 6 kw
AC 90 AF			1 x 9 kw				2 x 8 kw 1 x 9 kw
AC 100			2 x 6 kw				1 x 9 kw 1 x 6 kw
AC 100 AF			2 x 6 kw				3 x 9 kw
AC 120			2 x 6 kw			1 x 4,2 kw	1 x 6 kw 1 x 9 kw
AC 120 AF			2 x 6 kw			1 x 4,2 kw	3 x 9 kw
AC 150			2 x 6 kw				2 x 8 kw
AC 150 AF			2 x 6 kw				2 x 9 kw 1 x 10 kw
AC 170			2 x 6 kw			1 x 4,2 kw	2 x 8 kw
AC 170 AF			2 x 6 kw			1 x 4,2 kw	2 x 9 kw 1 x 10 kw
AC 200			2 x 6 kw	2 x 6 kw		1 x 4,2 kw	2 x 9 kw
AC 200 AF			2 x 6 kw	2 x 6 kw		1 x 4,2 kw	3 x 9 kw 1 x 6 kw*

	220/380	240/415
4,2 kw	110331	110331
5 kw	110371	110354
6 kw	110349	110383

	220/380	240/415
8 kw	110343	110365
9 kw	110362	110343
10 kw	110388	110381

- * 2 ° Boliler
- 2 ° surchauffeur
- 2 ° boiler
- 2. Boiler
- 2 ° boiler

26 - Heating Elements

CODE	DESCRIPTION
110331	HEAT.ELEMENT 4200W 230/400V
110343	HEAT.ELEM. 8000W 220/380V
110349	HEAT.ELEMENT 6000W 230/400V
110354	HEAT.ELEMENT 6000W 255/440V
110362	HEAT.ELEMENT 9000W 220/380V
110365	HEAT.ELEM. 9000W 255/440V-8KW
110371	HEAT.ELEMENT 5000W 220/380V
110381	HEAT.ELEMENT 12500W 254/440V
110383	HEAT.ELEMENT 6KW 240/415
110388	HEAT.ELEMENT 10000W 230/400V

27 - Electrical parts for heatings elements

kw	220/240 V				380/415 V			
	A	FUSIBILI FUSIBLE FUZE SCHMELZSICHERUNG FUSIBLE	A	TELERUTTORE CONTACTEUR CONTACTOR SCHALTSCHÜTZ CONTACTOR	A	FUSIBILI FUSIBLE FUZE SCHMELZSICHERUNG FUSIBLE	A	TELERUTTORE CONTACTEUR CONTACTOR SCHALTSCHÜTZ CONTACTOR
3,00	12	130246	9	120428	8	130245	9	120428
4,00	12	130246	9	120428	8	130245	9	120428
4,20	12	130246	9	120428	8	130245	9	120428
5,00	16	130247	12	120429	12	130246	9	120428
6,00	20	130248	12	120429	12	130246	9	120428
8,00	32	130237	25	120437	16	130247	12	120429
9,00	32	130237	25	120437	16	130247	16	120430
10,00	32	130237	25	120437	20	130248	16	120430
12,00	40	130238	40	120431	25	130236	16	120430
12,50	40	130238	40	120431	25	130236	25	120437
14,00	40	130238	40	120431	32	130237	25	120437
15,00	50	130257	40	120431	32	130237	25	120437
16,00	50	130257	40	120431	32	130237	25	120437
17,00	50	130257	40	120431	32	130237	40	120431
18,00	63	130239	63	120431	32	130237	40	120431
20,00	63	130239	63	120433	40	130238	40	120431
21,00	63	130239	63	120433	40	130238	40	120431
22,00	63	130239	63	120433	40	130238	40	120431
23,00	80	130240	63	120433	40	130238	40	120431
24,00	80	130240	63	120433	50	130257	40	120431
25,00	80	130240	63	120433	50	130257	40	120431
26,00	80	130240	80	120441	50	130257	40	120431
27,00	80	130240	80	120441	50	130257	40	120431
28,00	80	130240	80	120441	50	130257	40	120431
29,00	80	130240	80	120441	50	130257	40	120431
30,00	80	130240	80	120441	50	130257	40	120431

ASCIUGATURA - SECHAGE - DRYER TROCKNUNG - SECADO								
kw	220/240 V				380/415 V			
	A	FUSIBILI FUSIBLE FUZE SCHMELZSICHERUNG FUSIBLE	A	TELERUTTORE CONTACTEUR CONTACTOR SCHALTSCHÜTZ CONTACTOR	A	FUSIBILI FUSIBLE FUZE SCHMELZSICHERUNG FUSIBLE	A	TELERUTTORE CONTACTEUR CONTACTOR SCHALTSCHÜTZ CONTACTOR
6	20	130248	12	120429	12	130246	12	120429
9	25	130236	25	120437	16	130247	25	120437
12	40	130238	40	120431	25	130236	25	120437

27 - Electrical parts for heatings elements

CODE	DESCRIPTION
120428	CONTACTOR 9A 24V 50HZ
120429	CONTACTOR 12A 24V 50HZ
120430	CONTACTOR 17A 24V 50HZ
120431	CONTACTOR 40A 24V 50HZ
120433	CONTACTOR 63A 24V 50HZ
120437	CONTACTOR 25A 24V 50HZ
120441	CONTACTOR 80AMP 24V 50HZ
130236	FUSE 14X51 25A GF14325
130237	FUSE 14X51 32A GL14332
130238	FUSE 14X51 40A GF 14340
130239	FUSE 22X58 63A GF15363
130240	FUSE 22X58 80A GF15380
130245	FUSE 10.3X38 8A GF13308
130246	FUSE 10.3X38 12A GF13312
130247	FUSE 10.3X38 16A GF13316
130248	FUSE 20A-10,3X38 13320 G.F.
130257	FUSE 50A 14X51 GF14350

28 - Electrical parts for pumps

220/240 V								380/415 V					
POMPA POMPE PUMP PUMPE BOMBA		FUSIBILI FUSIBLE FUZE SCHMELZSICHERUNG FUSIBLE		TELERUTTORE CONTACTEUR CONTACTOR SCHALTSCHÜTZ CONTACTOR		TERMICA TERMIQUE OVERLOAD RELAY THERMOAUSLÖSER TERMICO		FUSIBILI FUSIBLE FUZE SCHMELZSICHERUNG FUSIBLE		TELERUTTORE CONTACTEUR CONTACTOR SCHALTSCHÜTZ CONTACTOR		TERMICA TERMIQUE OVERLOAD RELAY THERMOAUSLÖSER TERMICO	
HP	kw												
0,10	0,08	4	130230	9	120428	0,63 - 1,00	120820	4	130230	9	120428	0,40 - 0,63	120830
0,12	0,09	4	130230	9	120428	0,63 - 1,00	120820	4	130230	9	120428	0,40 - 0,63	120830
0,15	0,11	4	130230	9	120428	0,63 - 1,00	120820	4	130230	9	120428	0,63 - 1,00	120820
0,17	0,12	4	130230	9	120428	1,00 - 1,60	120821	4	130230	9	120428	0,63 - 1,00	120820
0,2	0,15	4	130230	9	120428	1,00 - 1,60	120821	4	130230	9	120428	0,63 - 1,00	120820
0,22	0,17	4	130230	9	120428	1,00 - 1,60	120821	4	130230	9	120428	0,63 - 1,00	120820
0,25	0,18	4	130230	9	120428	1,60 - 2,50	120822	4	130230	9	120428	1,00 - 1,60	120821
0,4	0,30	4	130230	9	120428	1,60 - 2,50	120823	4	130230	9	120428	1,00 - 1,60	120821
0,5	0,37	4	130230	9	120428	1,60 - 2,50	120823	4	130230	9	120428	1,00 - 1,60	120821
0,6	0,44	4	130230	9	120428	2,50 - 4,00	120823	4	130230	9	120428	1,00 - 1,60	120821
0,75	0,55	4	130230	9	120428	2,50 - 4,00	120823	4	130230	9	120428	1,60 - 2,50	120822
1	0,75	4	130230	9	120428	2,50 - 4,00	120820	4	130230	9	120428	1,60 - 2,50	120822
1,01	0,76	4	130230	9	120428	2,50 - 4,00	120824	4	130230	9	120428	1,60 - 2,50	120822
1,4	1,10	8	130232	9	120428	4,00 - 6,00	120825	6	130231	9	120428	2,50 - 4,00	120823
1,5	1,11	8	130232	9	120428	4,00 - 6,00	120825	6	130231	9	120428	4,00 - 6,00	120823
2	1,50	8	130232	9	120428	5,50 - 8,00	120828	6	130231	9	120428	4,00 - 6,00	120823
2,7	2,00	8	130232	9	120428	5,50 - 8,00	120828	6	130231	9	120428	4,00 - 6,00	120823
3	2,20	12	130234	9	120428	7,00 - 10,00	120826	6	130231	9	120428	4,00 - 6,00	120823
3,2	2,40	12	130234	12	120429	7,00 - 10,00	120826	6	130231	9	120428	4,00 - 6,00	120823
3,5	2,60	12	130234	12	120429	10,00 - 13,00	120826	6	130231	9	120428	5,50 - 8,00	120825
3,6	2,70	16	130235	12	120429	10,00 - 13,00	120826	8	130232	9	120428	5,50 - 8,00	120825
3,70	2,72	16	130235	12	120429	10,00 - 13,00	120826	6	130231	9	120428	5,50 - 8,00	120825
4,0	3,00	16	130235	16	120430	10,00 - 13,00	120826	12	130234	12	120429	5,50 - 8,00	120825
5,3	4,00	20	130235	18		13,00 - 18,00		16	130235	12	120429	7,00 - 10,00	120828

28 - Electrical parts for pumps

CODE	DESCRIPTION
120428	CONTACTOR 9A 24V 50HZ
120429	CONTACTOR 12A 24V 50HZ
120430	CONTACTOR 17A 24V 50HZ
120820	OVERLOAD RELAY 0,63-1A
120821	OVERLOAD RELAY 1/1,6A
120822	OVERLOAD RELAY 1,6-2,5A
120823	OVERLOAD RELAY 2.5/4 A
120824	OVERLOAD RELAY 4/6 A
120825	OVERLOAD RELAY 5,5/8 A
120826	OVERLOAD RELAY 10/13A
120828	OVERLOAD RELAY 7/10 A
120830	OVERLOAD RELAY 0,40 - 0,63 A
130230	FUSE 10,3X38 4A AM13004
130231	FUSE 10,3X38 6A AM13006
130232	FUSE 10.3X38 8A AM13008
130234	FUSE 10.3X38 12A AM13012
130235	FUSE 10.3X38 16A AM13016